

Composites Technology

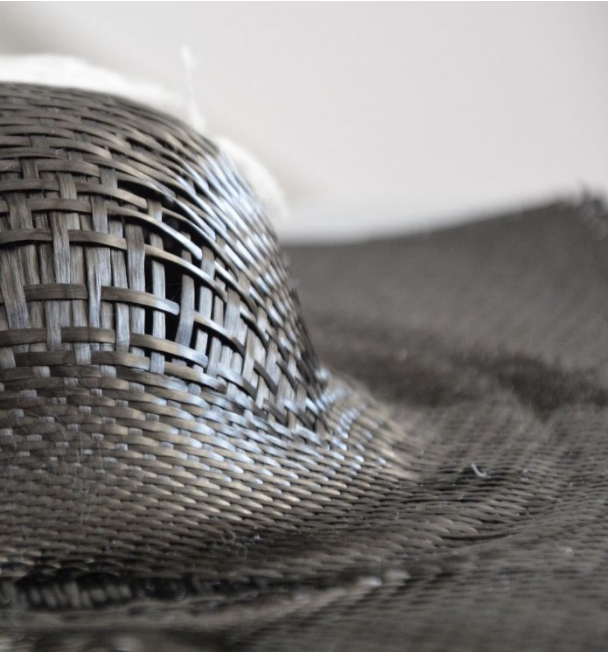

Textile composites

pierre-etienne.bourban@epfl.ch

Institut des matériaux (IMX)
Ecole Polytechnique Fédérale de Lausanne (EPFL),
CH-1015 Lausanne

More info...

I. Verpoest, S. Lomov, KUL
« *Composite Preforming techniques* »,
Comprehensive Composite Materials, Elsevier 2000

O. Rozant *et al.*, *Drapability of Dry Textile Fabrics for Stampable Thermoplastic Preforms*, Composites Part A

G. Nemoz, « *Textures textiles tridimensionnelles* »,
Techniques de l'ingénieur, traité plastiques et composites



<https://www.mtm.kuleuven.be/onderzoek/scalint/Composites/software/wisetex>

<https://www.esi-group.com/products/composites>

Introduction

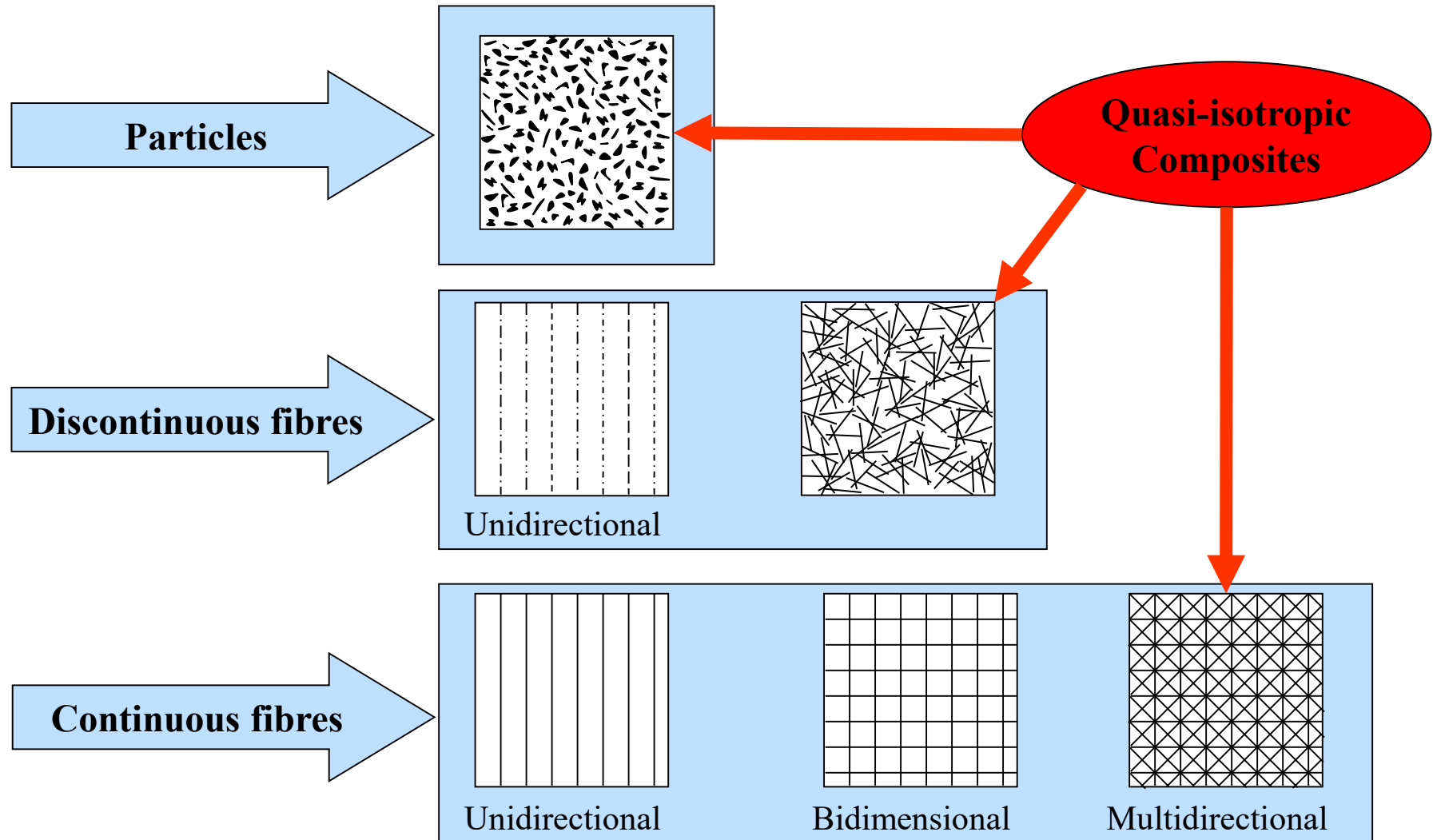

Textile composites

W...oven fibers

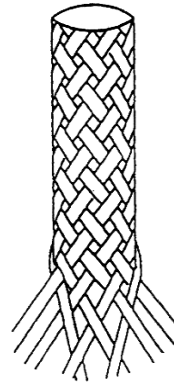
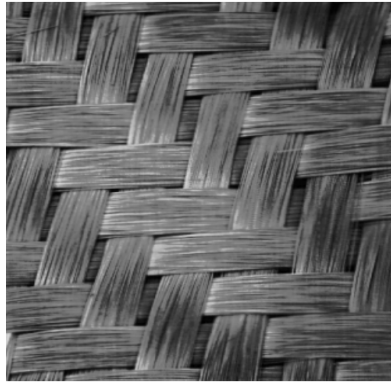

K...nitted fibers

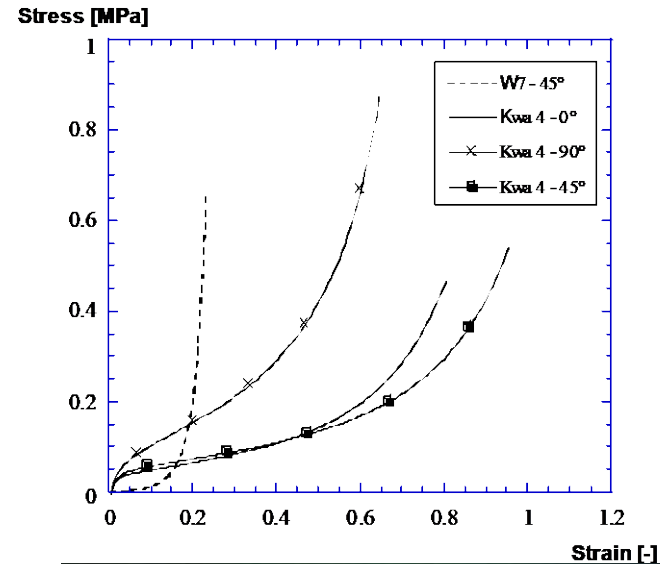

Classification of textile structures

Woven fabrics are produced by weaving continuous fibres, while knitted fabrics have a structure formed by an intermeshing of yarn loops. Braids are obtained by interlacing three or more threads in such a way that they cross one another and are laid together in a diagonal formation.

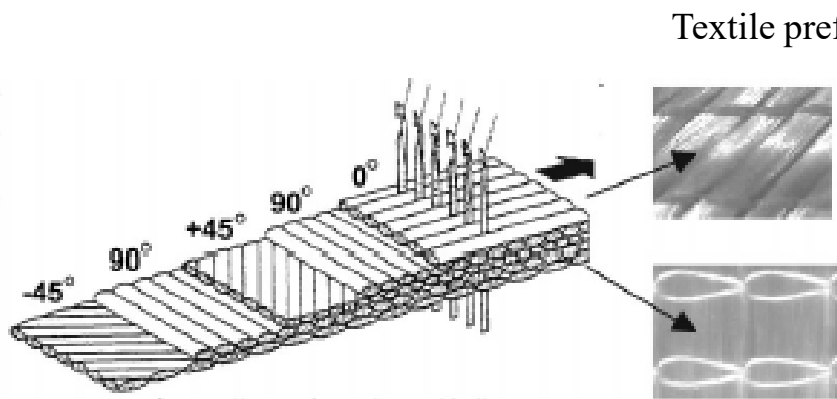
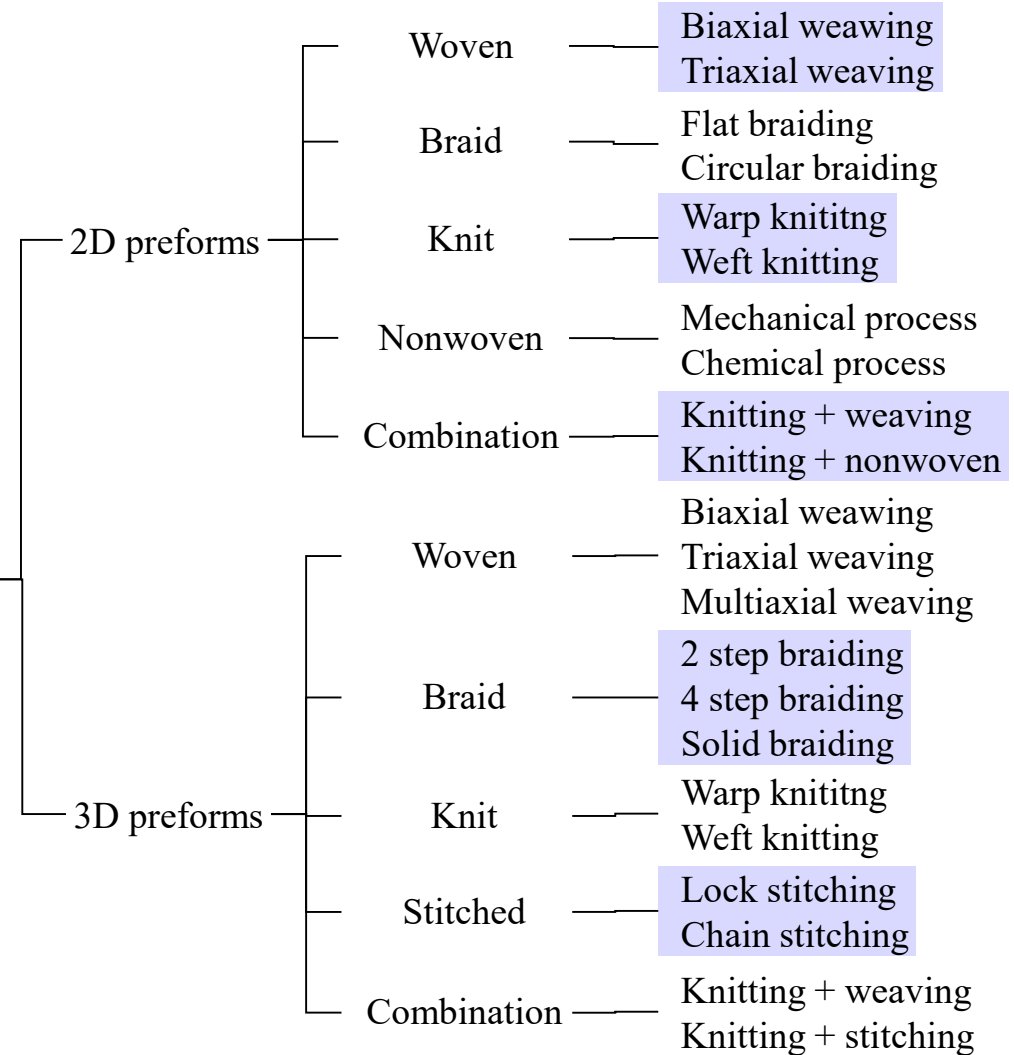

Figure 7 Multiaxial weft inserted warp knit (MWK).

Textile preforms



N.B.: weaving: tissage
knitting: tricotage
braiding: tressage

Woven structures

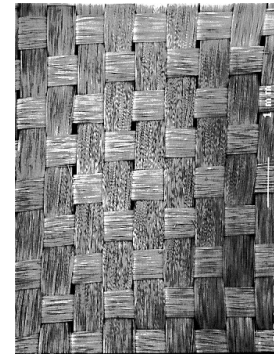
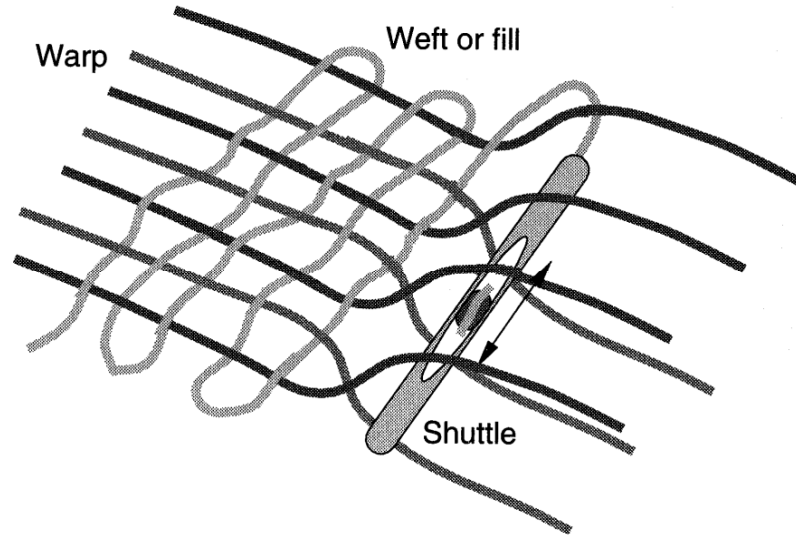

Plain weave



2/3 twill

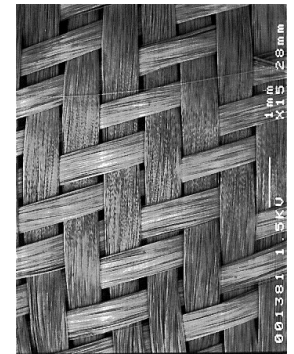

2/2 twill

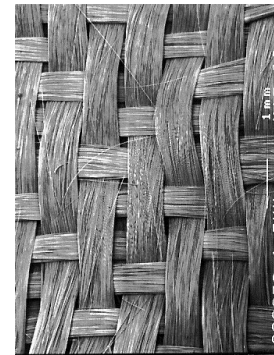

4 Harness satin

1mm

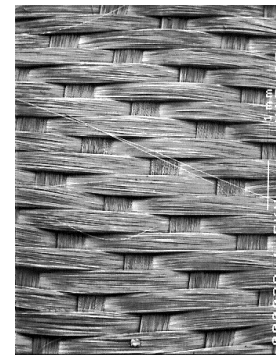

8 Harness satin

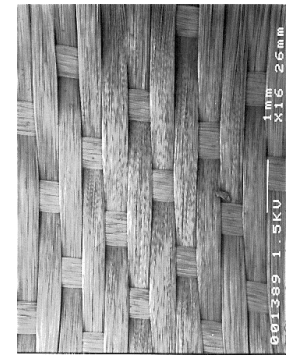

8 Harness satin

N.B.: warp: chaîne
weft: trame

Woven structures

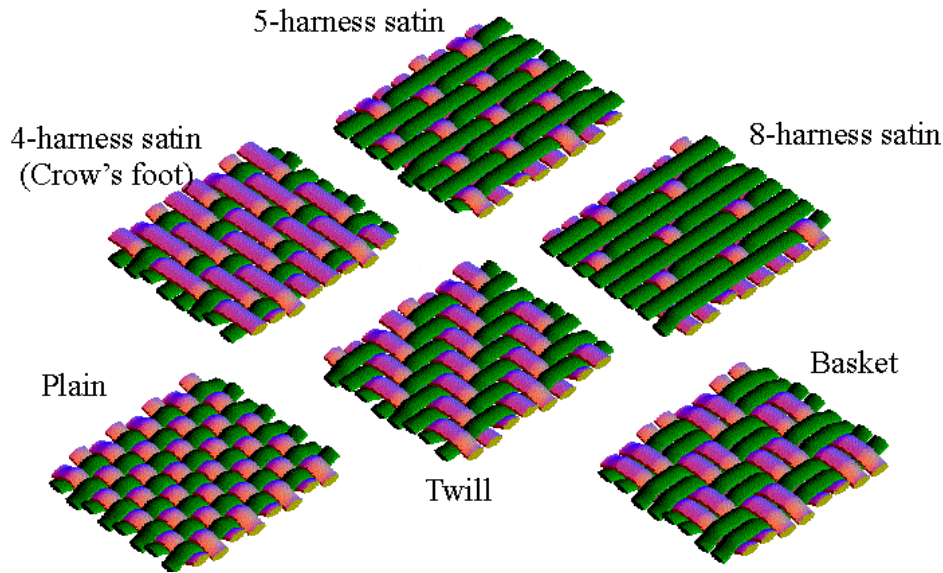

Plain weave (« taffetas » or « toile »)

Each weft wire passes alternately over and under each warp wire and each warp wire passes alternately over and under each weft wire.

This fabric is symmetrical, with maximum stability and firmness with minimum yarn slippage. It has good strength in the 2 yarn directions but it is most difficult to drape, and the high level of crimp provides lower mechanical properties compared with the other weave styles. It is usually left moderately open so that the resin penetration is fair to good.

Twill weave (« sergé »)

Each weft wire alternately passes over 2, then under 2 successive warp wires and each warp wire passes alternately over two and under two successive weft wires, in a staggered arrangement.

Superior wet out and drape is seen in the twill weave over the plain weave with only a small reduction in stability.

Satin weave (« satin »)

Satin weaves are fundamentally twill weaves modified to produce fewer intersections of warp and weft. The harness number used in the designation (4, 5, 8, 12) is the total number of fibres crossed and passed under, before the fibre repeats the pattern.

Satin weaves are flat, have a good wet out and a high degree of drape. Satin weaves are favored as planar woven fabric reinforcement for composites due to their long floats and less crimp. The low crimp gives good mechanical properties. This loos weave structure is also easily penetrated by resin matrices. This weave has good conformability but is not suitable for applications requiring a high level of preform dimensional stability. Moreover the asymmetry of the weave needs to be considered.

3D fabrics

Comparison of conventional 2D weaving and 3D weaving:

2D Weaving Process

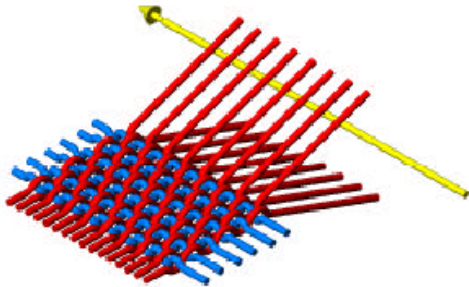

Unavoidable crimp in at least one yarn

True 3D Weaving

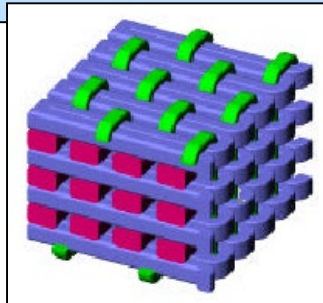
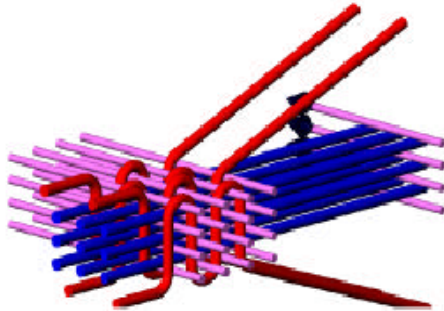

Thicker fabrics
Less fiber damage
Lower crimp

Examples of 3D woven fabric structures:

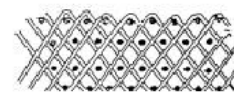

Warp Interlock

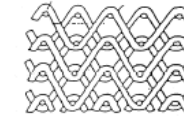

Angle Interlock

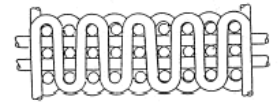

3D Orthogonal Weave

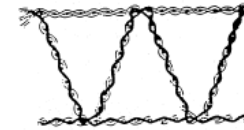

Open Core Structures

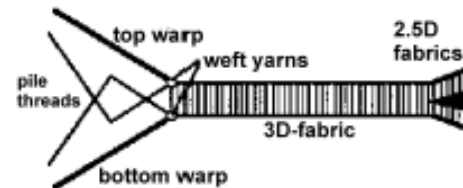

Figure 40 Schematic of velvet weave

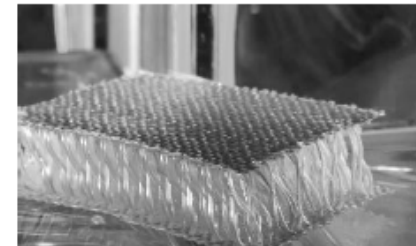
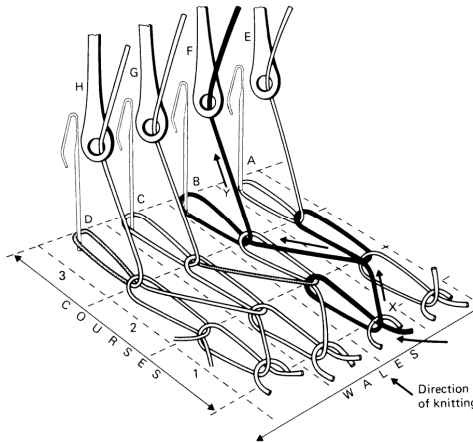
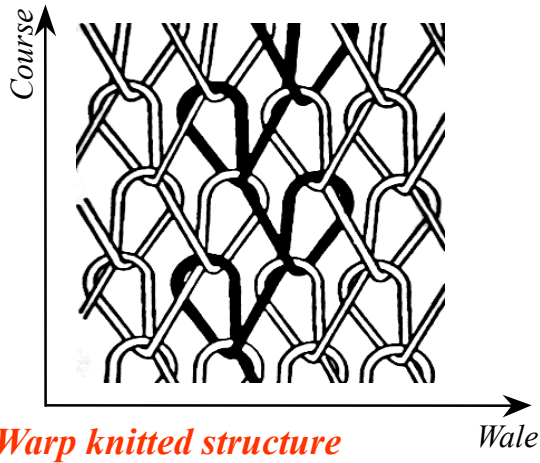
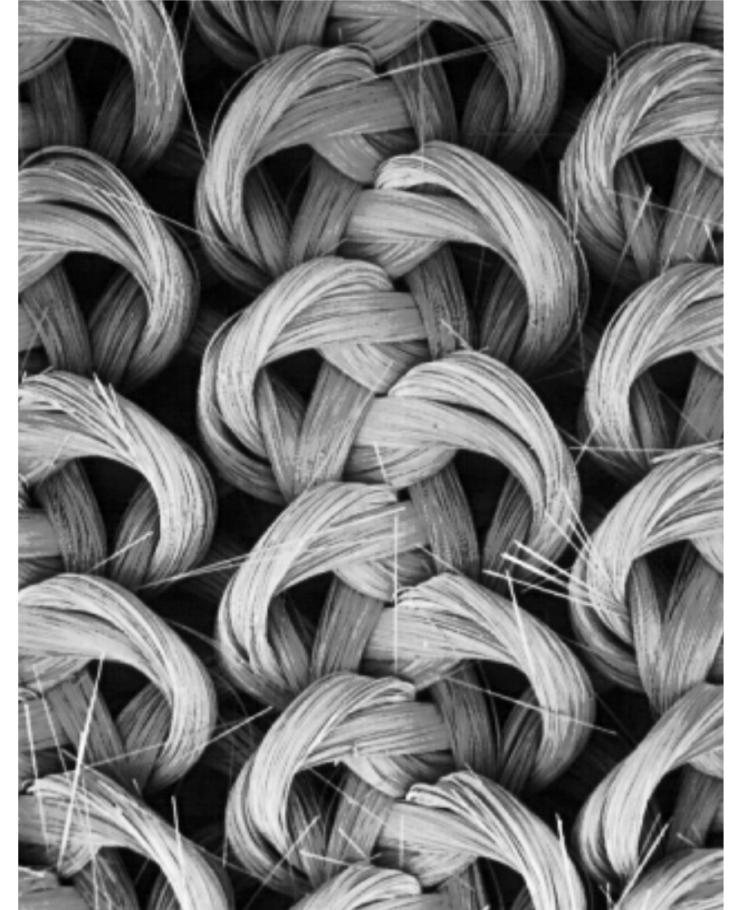
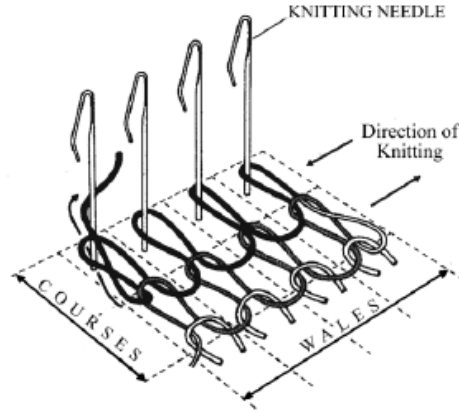
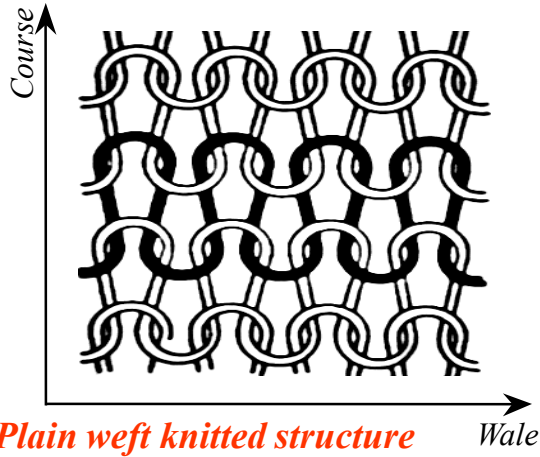

Figure 41 Sandwich-fabric preform.

3TEX Inc.

Knitted structures



Various knits

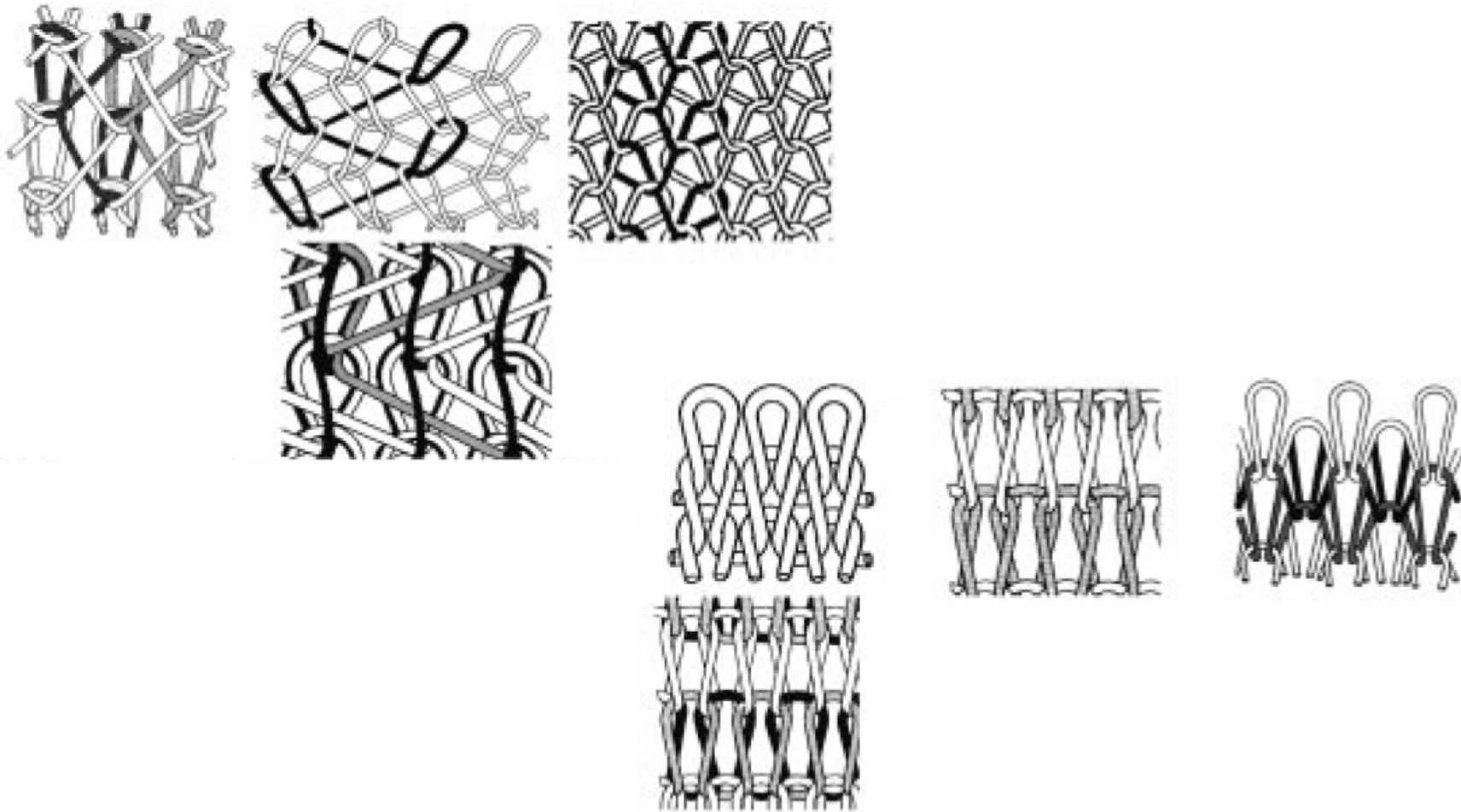

(a) Plain single jersey; (b) 1x1 rib; (c) full cardigan; (d) full milano (after Spencer, 1997).

Knitted preforms

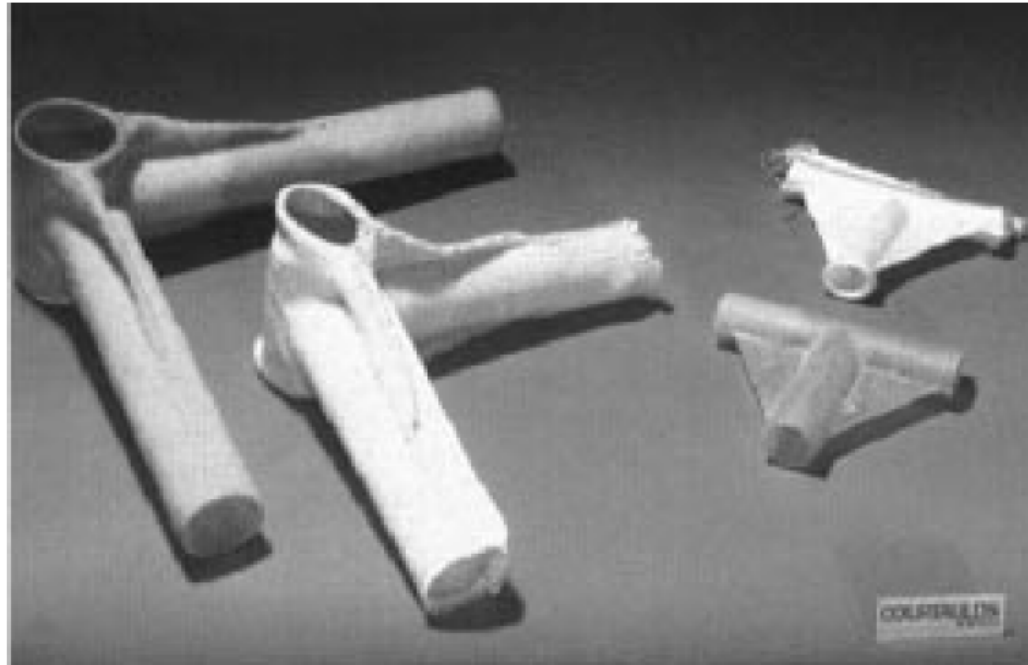
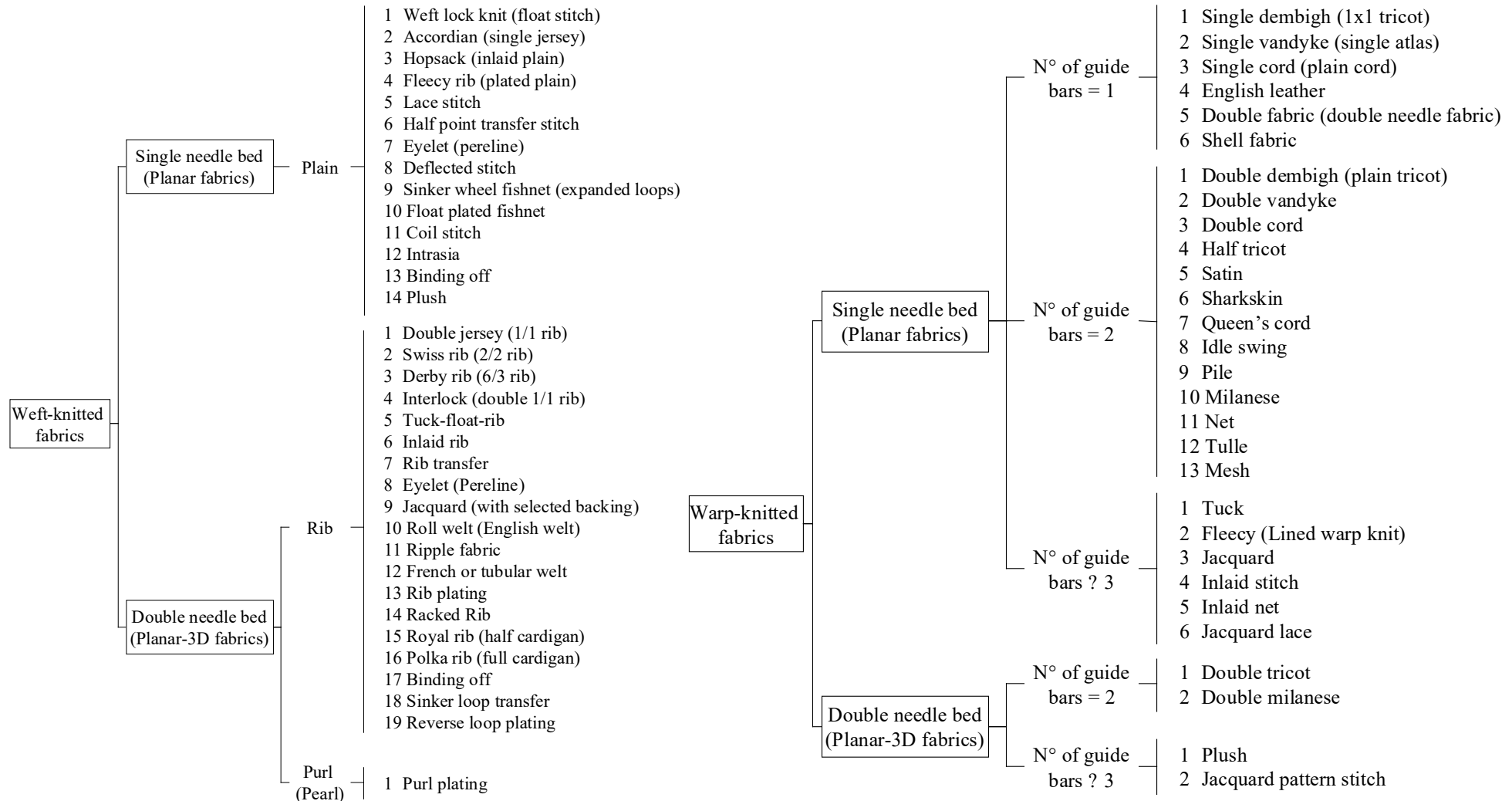

Figure 29 Examples of integrally weft-knitted preforms (after Williams, 1987).

Classification of knits



3D knits

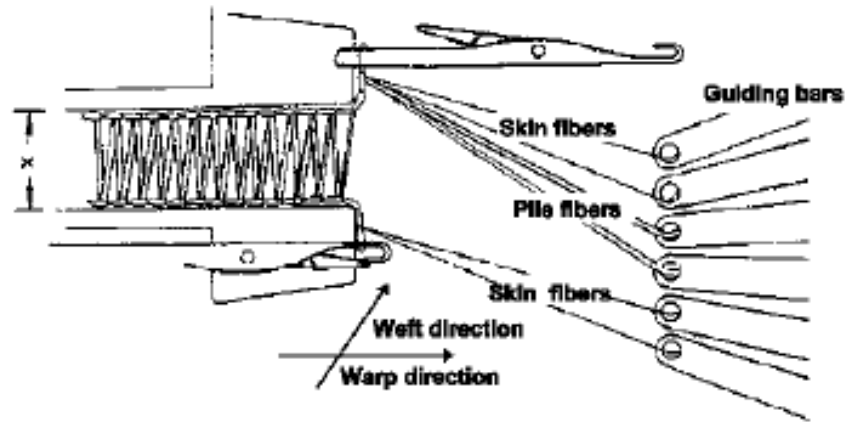
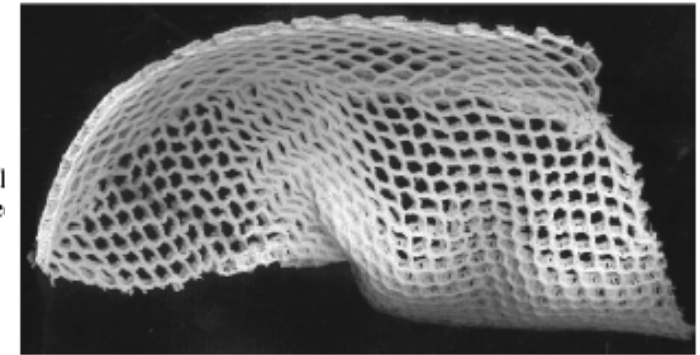

Figure 46 Schematic drawing of the 3-D knitting production process. Top and bottom skin of the textil are simultaneously knitted on the two beds of the Rashell knitting machine while the pile fibers are knitted in both skins so that they become connected.



Complex shape demonstrating the extreme drapability of open 3-D knits.

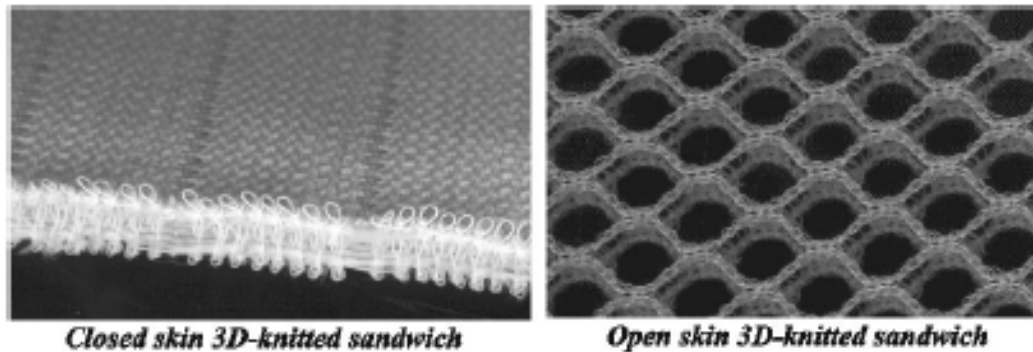
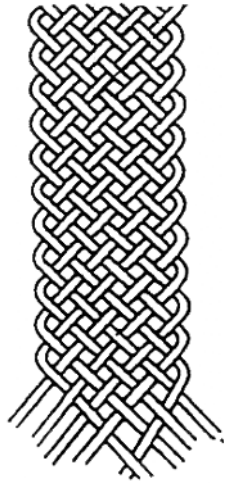

Figure 47 Comparison of a closed-skin 3-D knit with an open 3-D knit. The closed-skin knit is very similar to a 3-D weave.

Comparison of 3D structures

<i>Composite</i>	<i>Advantages</i>	<i>Disadvantages</i>
3-D Woven	Good specific properties Good delamination and impact properties Efficient processing	The textiles are not drapable on double curved surfaces Closed skins
2-D Knitted	Textiles are extremely drapable Open structures are possible Controllable (an)isotropy	Fixed anisotropy Acceptable properties

Braids



flat

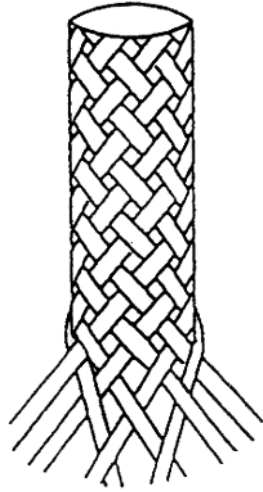

tubular

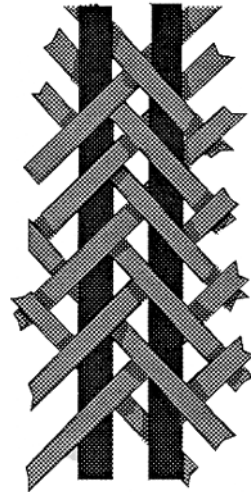

triaxial

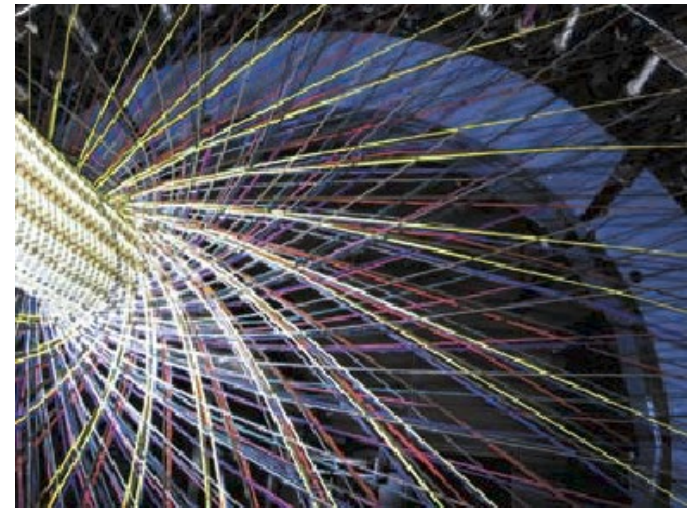
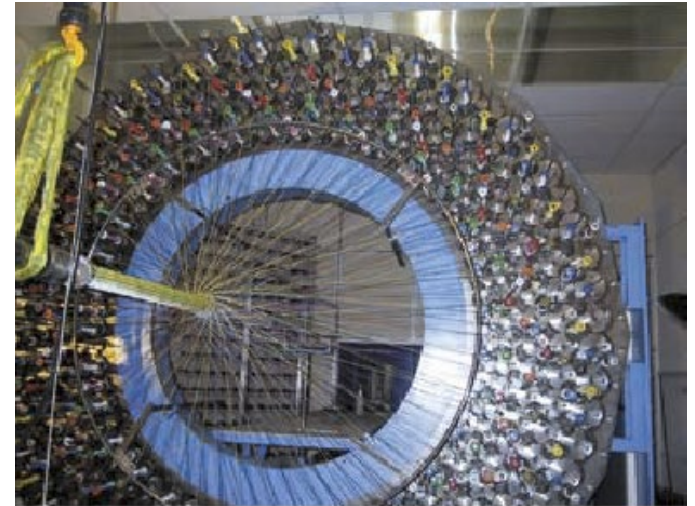
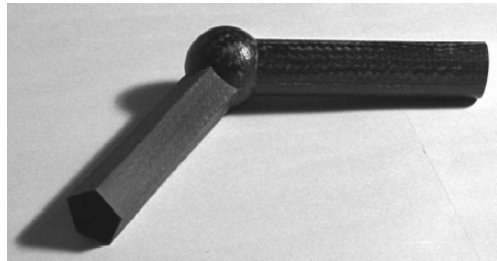
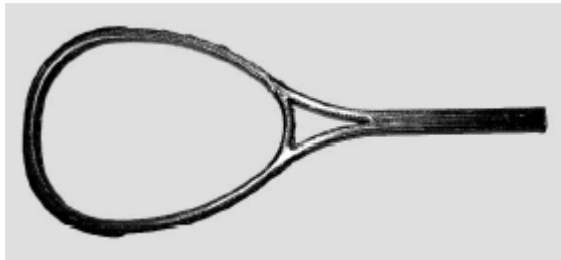



Deformation during processing

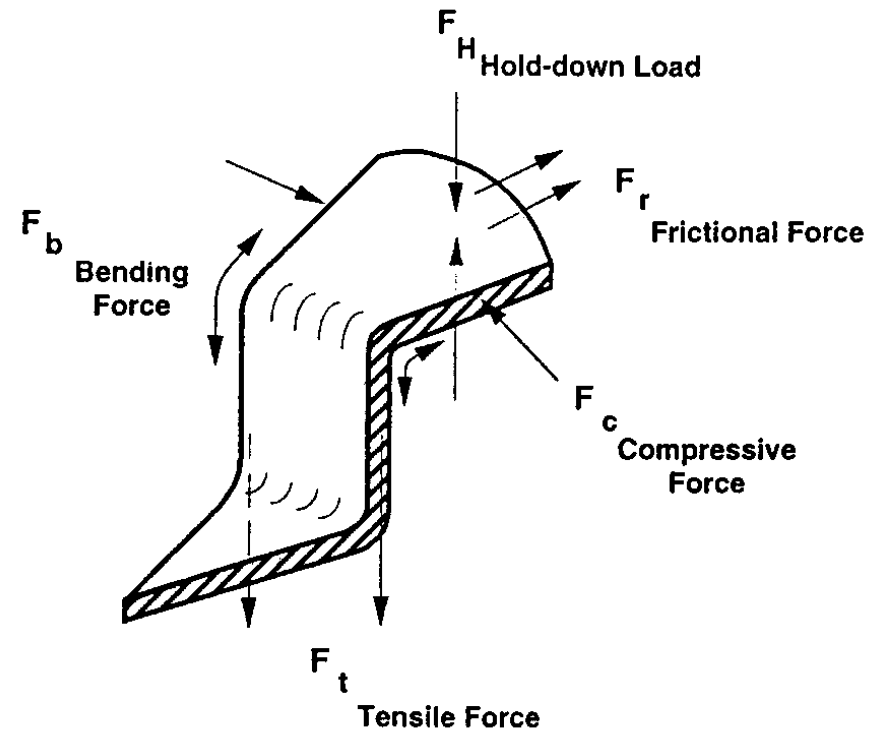
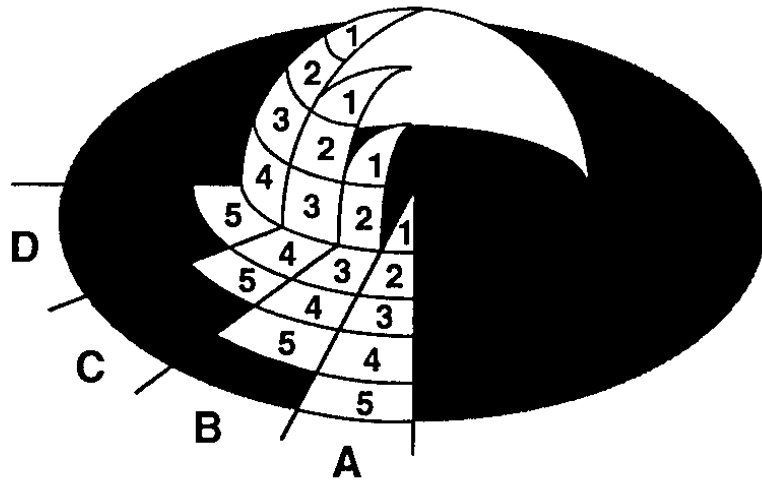

Tensile properties

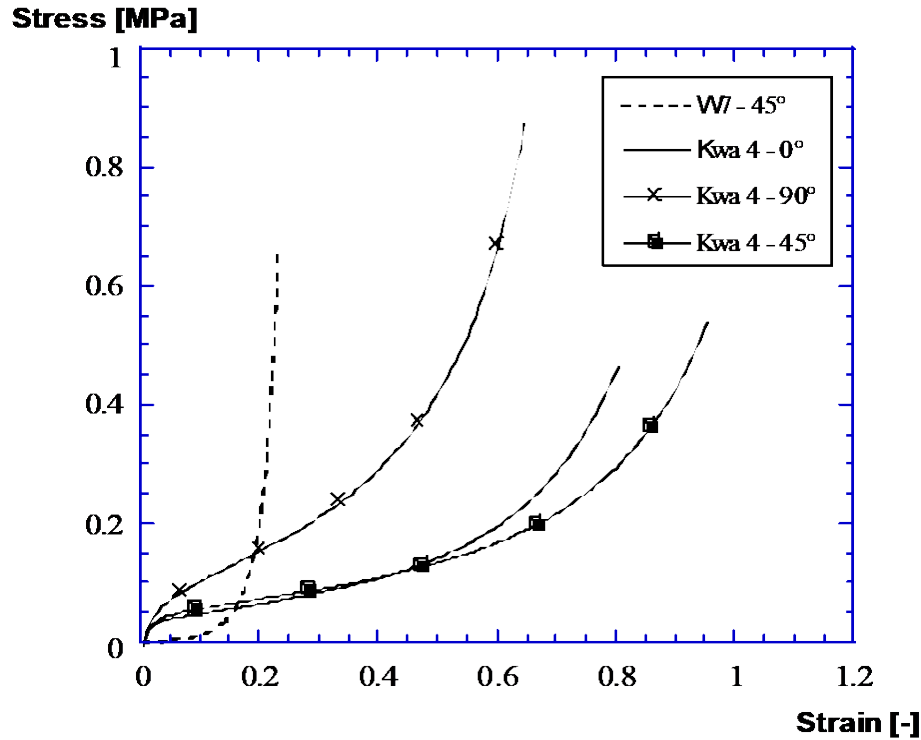

Dry Woven and Knits

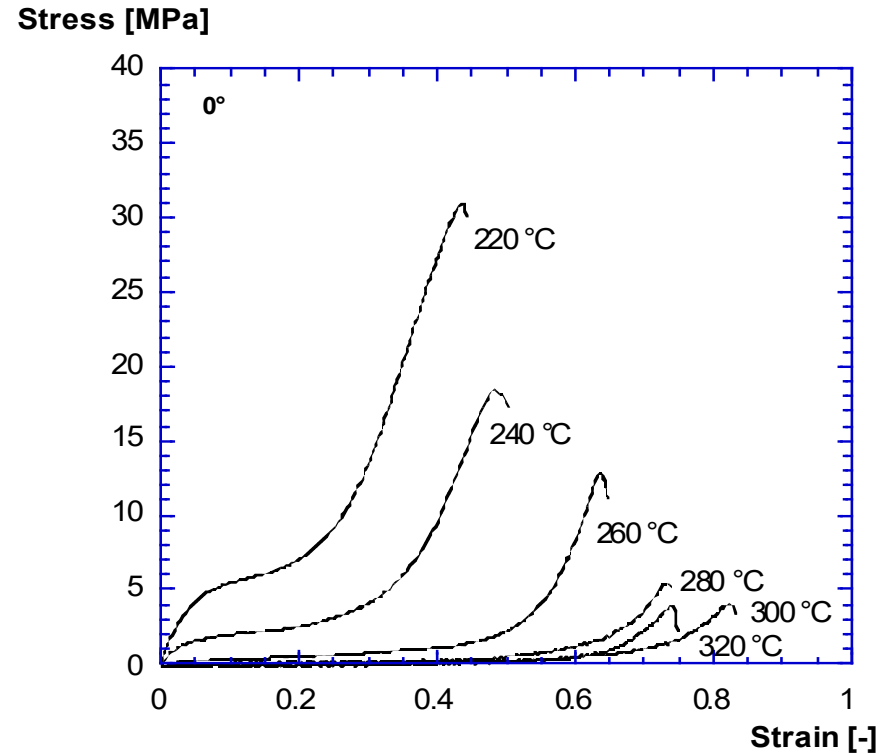

Knits tested at different temperatures

Tensile properties

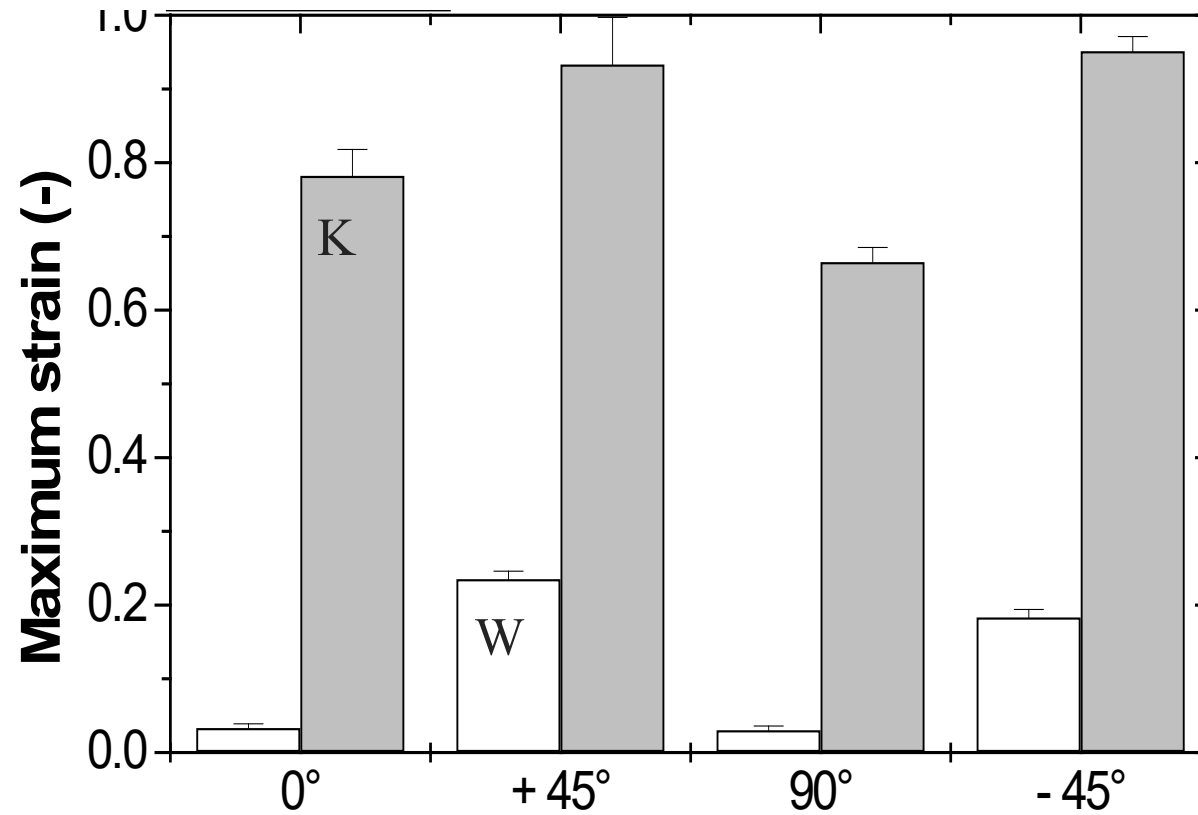

Tensile properties

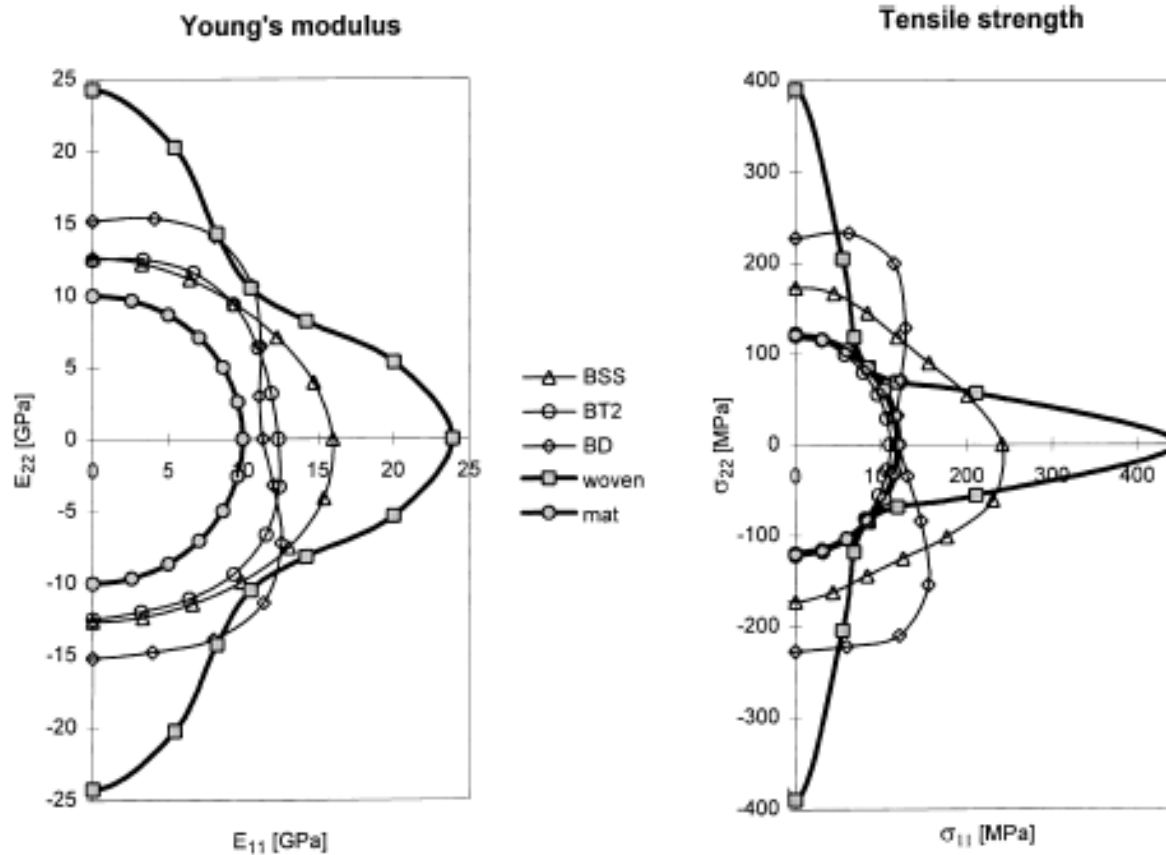

Figure 1 Polar plot of the Young's modulus and tensile strength for three knitted fabric composites (BSS, BT2 and BD), a woven fabric composite and a continuous fibre mat composite (all glass/epoxy)

B. Gommers, I. Verpoest and P. Houtte: « *Analysis of knitted fabric reinforced composites: Part II. Stiffness and strength* », Composites Part A: Applied Science and Manufacturing, 29, 12, 1998, pp 1589-1601

Deformation mechanisms of weaves



Stretching

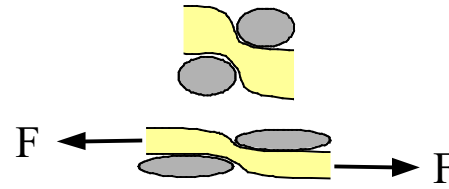

Uncrimping

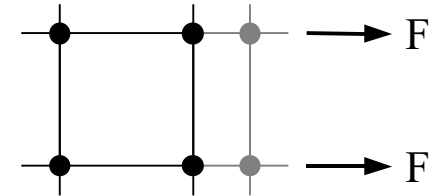

Shear slip

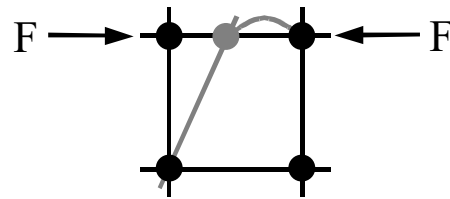

Buckling

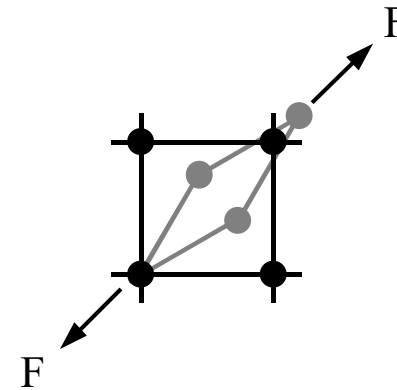

Shear

Deformation singularities

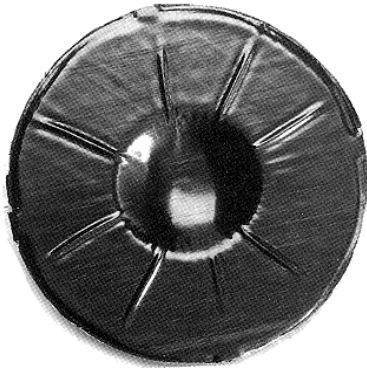

Initial state

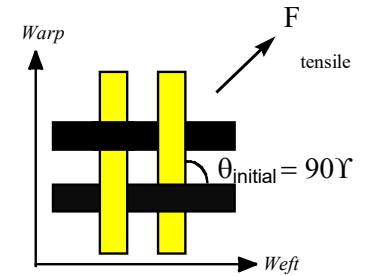

During shearing

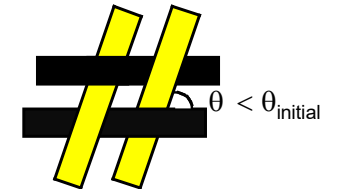
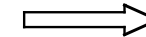

Further shearing

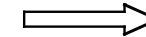

Locking angle

Deformation beyond locking angle

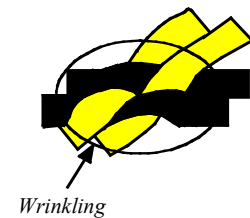
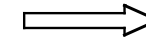

Wrinkling

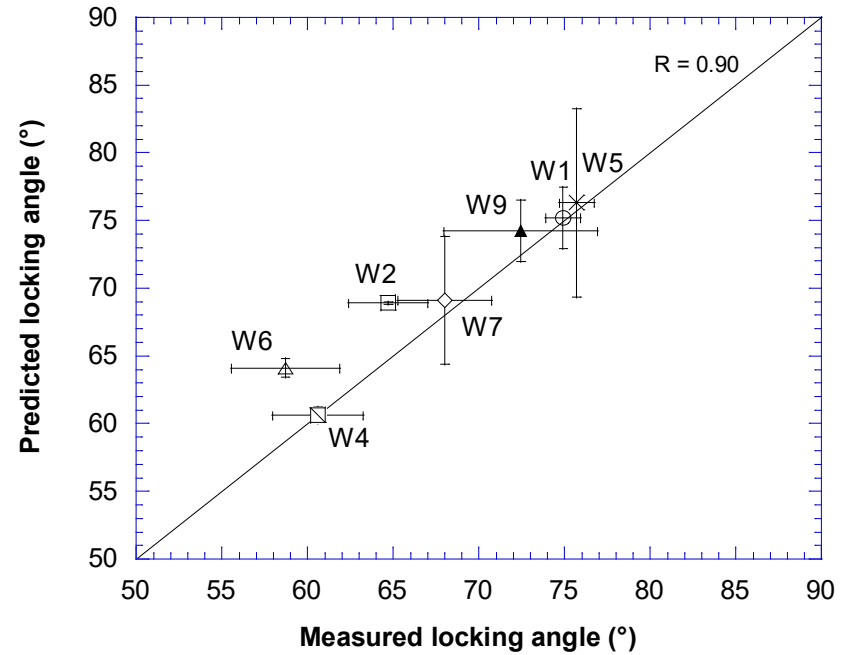
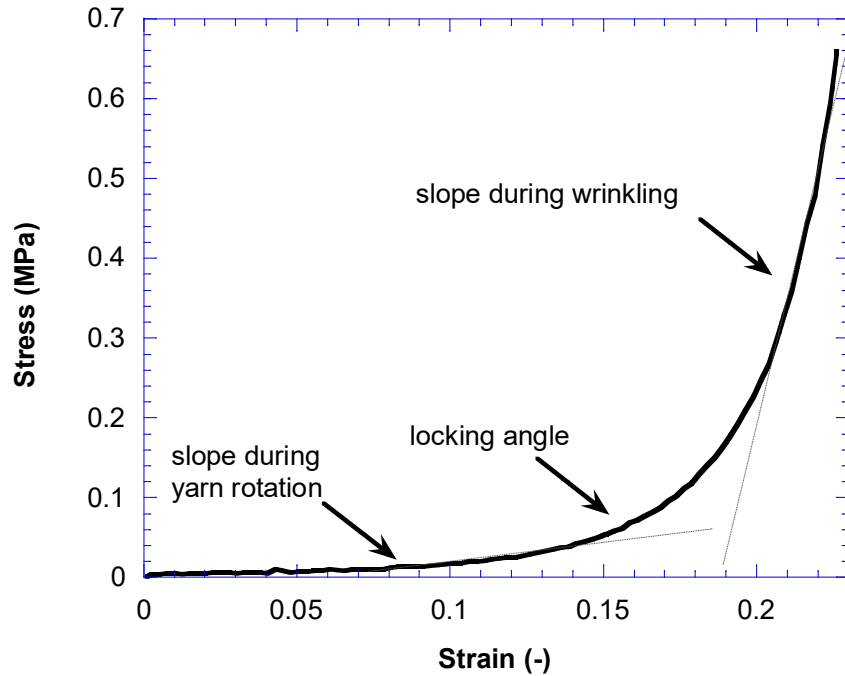

Wrinkling

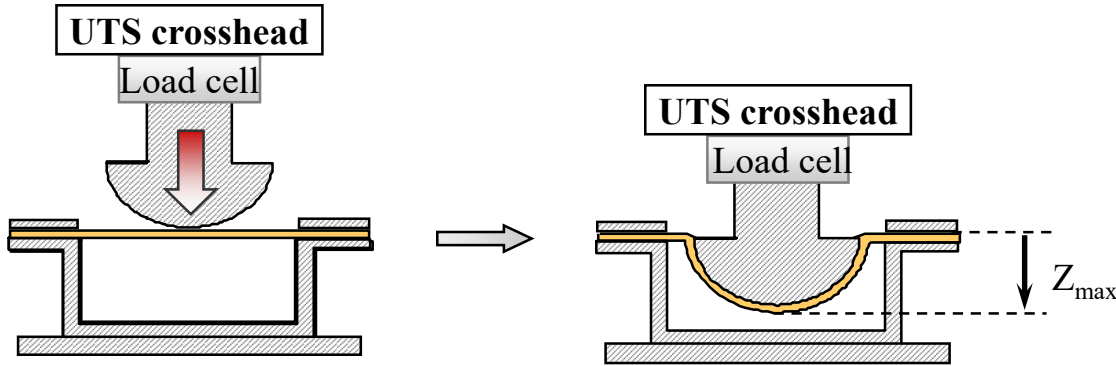

- ↖ formability
- ↖ stretchability
- ↖ forming energy

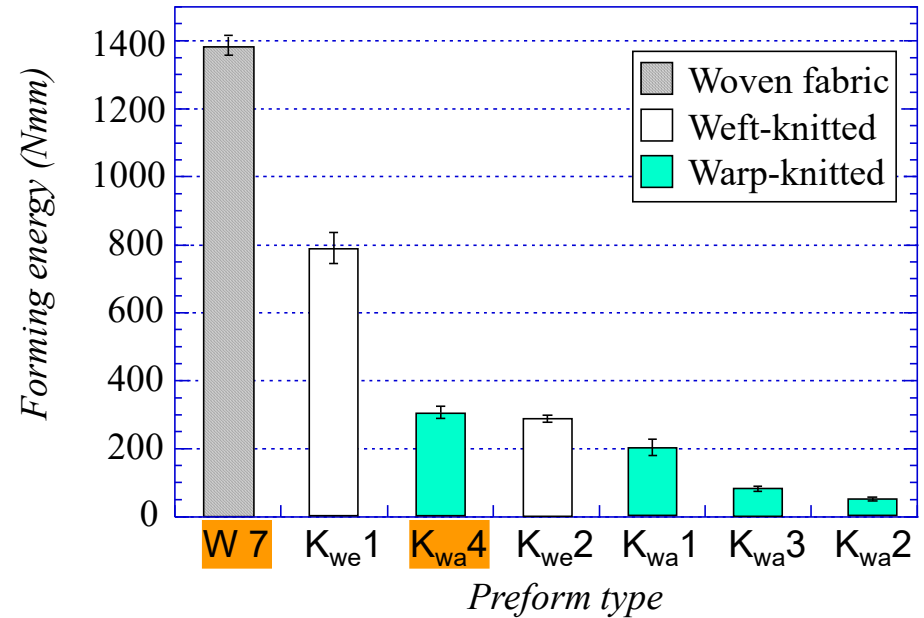
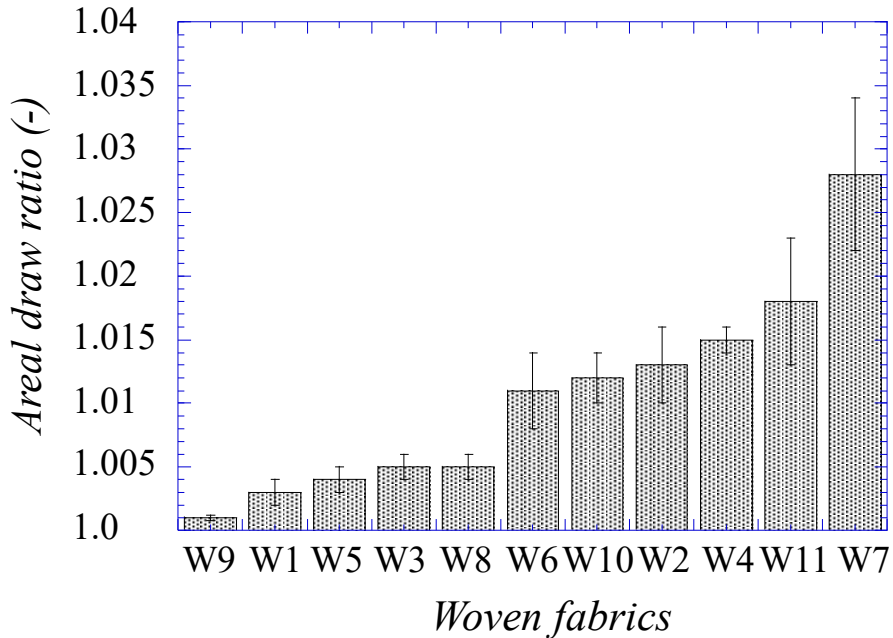

↖ Knitted fabric = low forming energy + no wrinkling

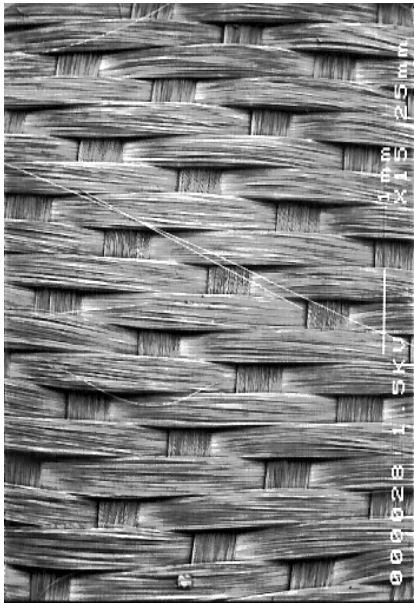

8 harness satin

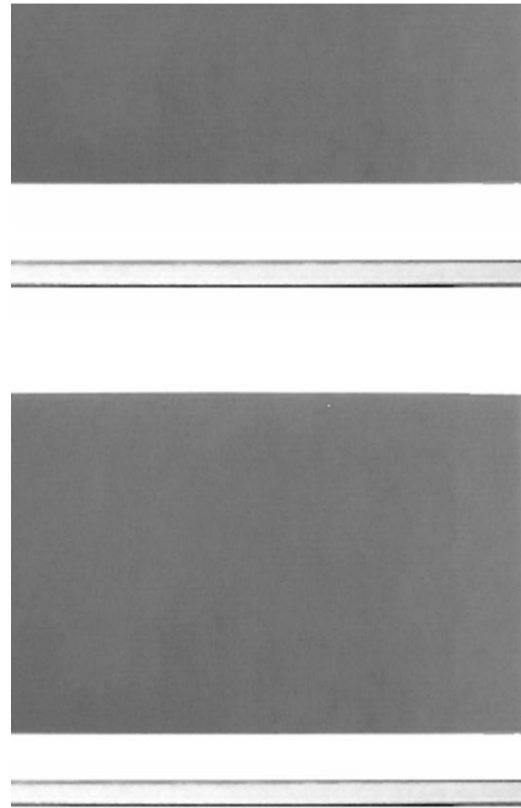

(a)

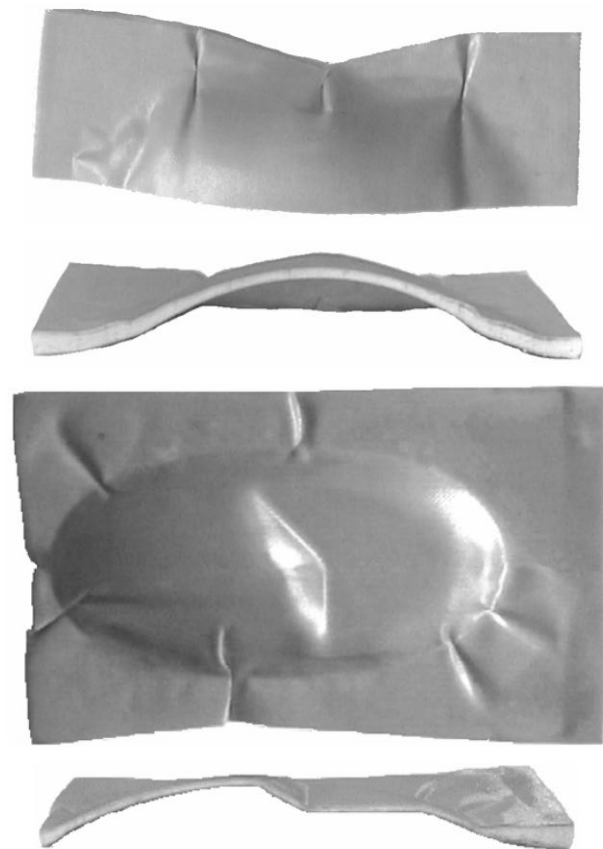

(b)

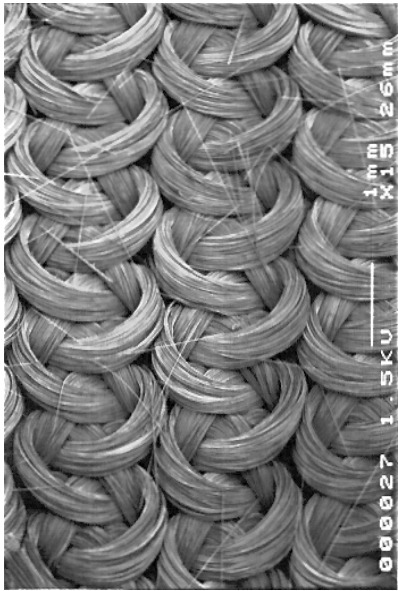

Warp knitted fabric

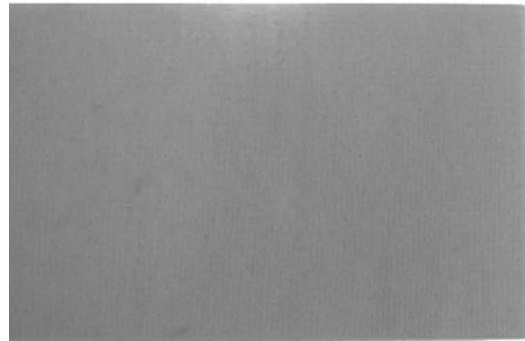
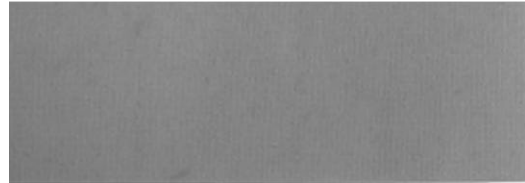

(a)

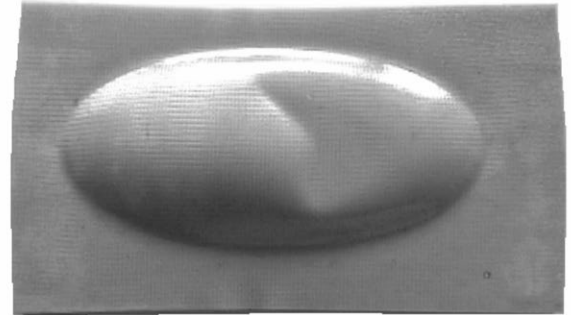
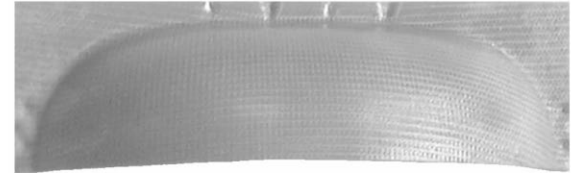

(b)

From textile structures to complex geometries

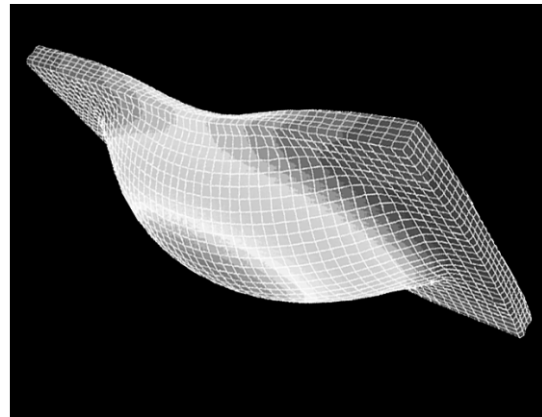
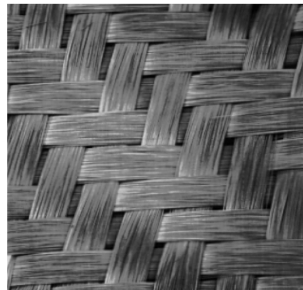
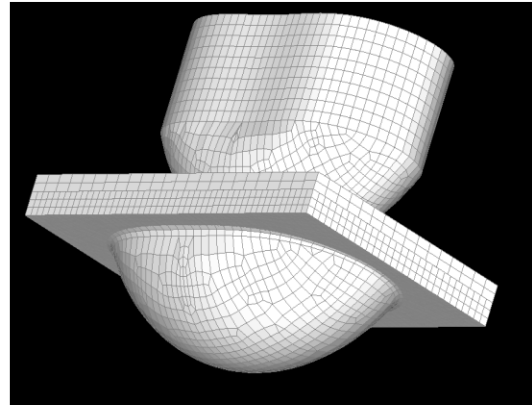

Thèse EPFL, O. Rozant,

Draping in Composites Design



Draping in Composites Design - Where?

- Composites CAE

» Modular software for a hierarchical design approach

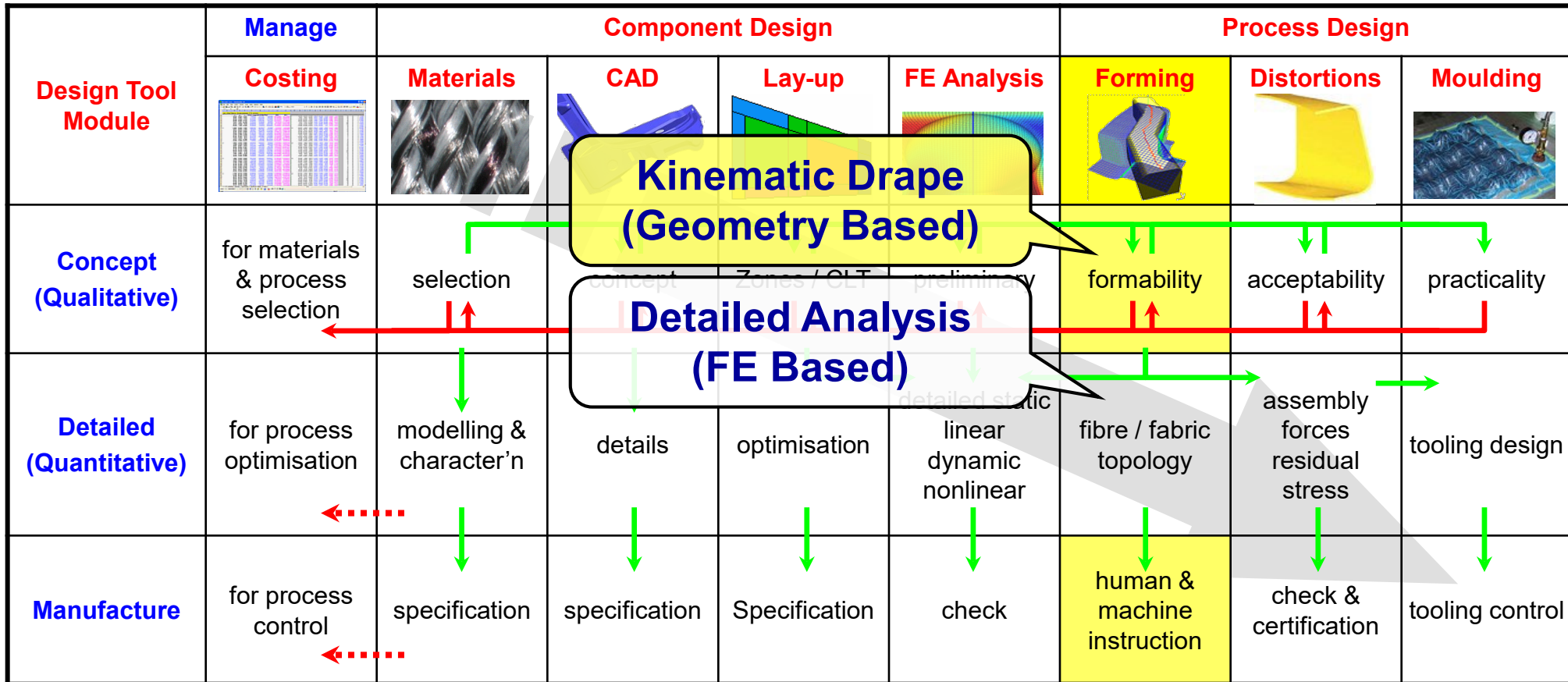

Lay-up Characterisation

- “The same shape can be formed in many ways”

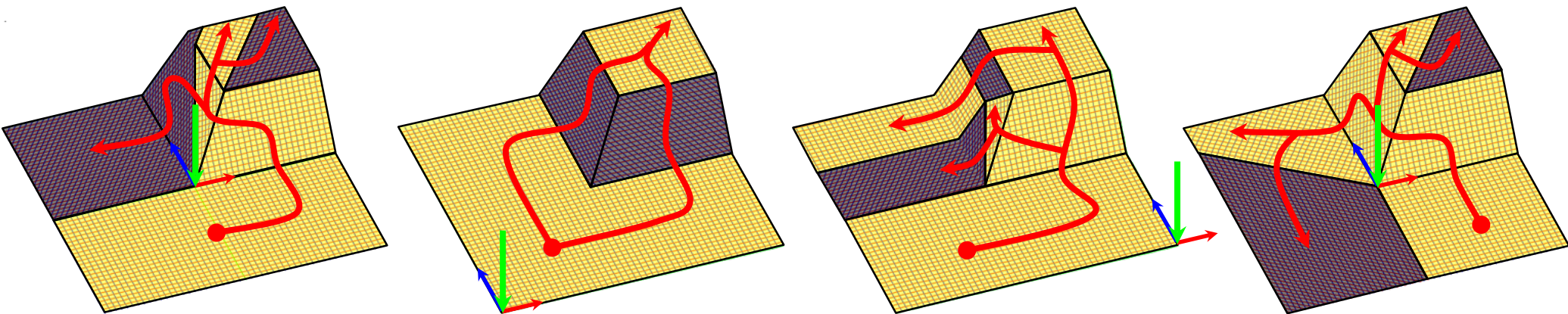
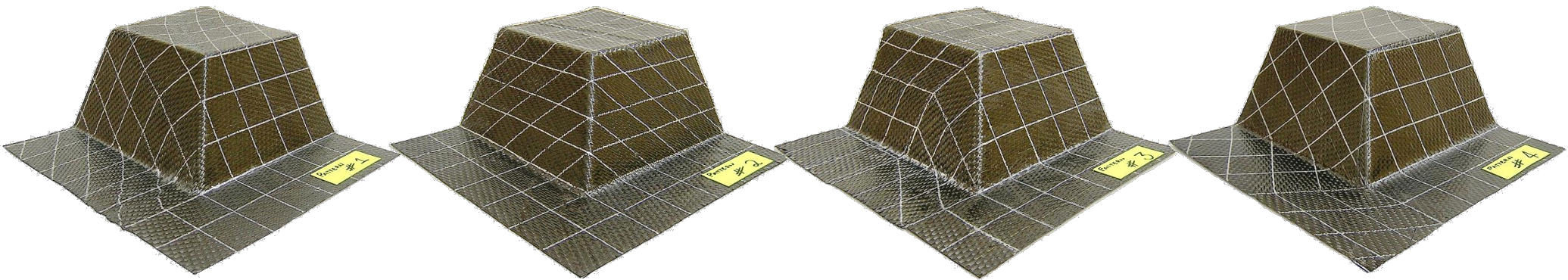

Draping and thermoforming simulation

PAM-FORM, the composite forming simulation module within PAM-COMPOSITES, is used to simulate the preforming process of dry textiles or the thermoforming process of fiber-reinforced composite materials made of thermoset or thermoplastic resins (organosheets, GFRP, CFRP...).

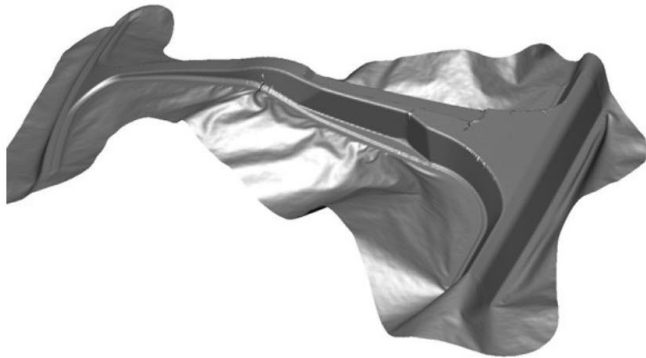

PAM-FORM allows you to model a wide range of processes including:

- stamping using two rigid molds
- rubber pad forming
- diaphragm forming
- and mo

This module can be used to predict phenomena such as:

- fiber orientation
- thickness distribution
- optimum initial flat pattern
- strains
- stresses
- bridging
- wrinkling

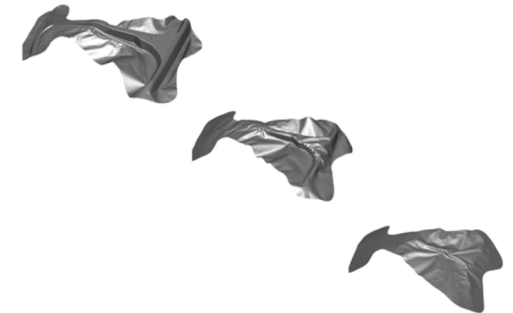

These results are available at the laminate level as well as at the ply level, allowing you to predict cases of internal wrinkles, for example, that are not visible through visual checks of physical prototypes. PAM-FORM includes material models for UniDirectional (UD), Non-Crimp Fabric (NCF), woven fabric, dry textile, thermoset prepreg, and organosheet.

With PAM-FORM, manufacturing defects are eliminated and product quality is improved upfront in the product development process, before any tools are cut, thanks to the optimization of the following process parameters:

- tool velocity
- temperature and pressure cycle
- clamping conditions and force
- laminate sequence, ply orientations
- tooling design

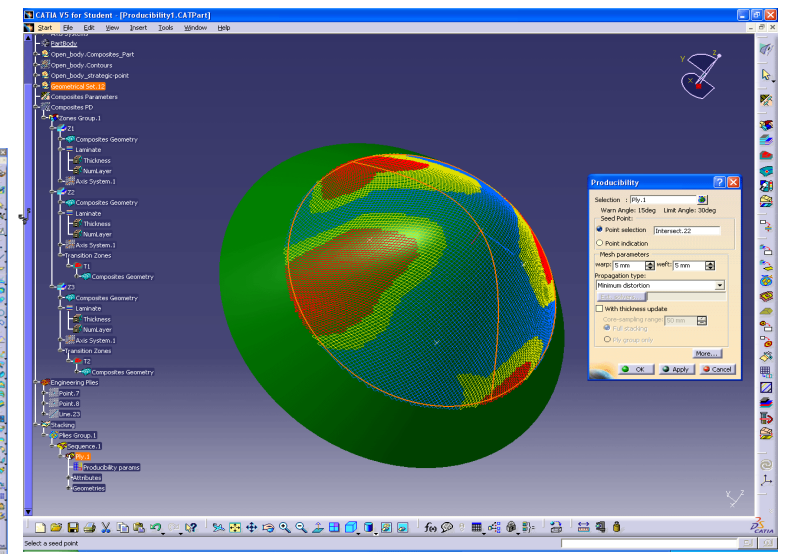
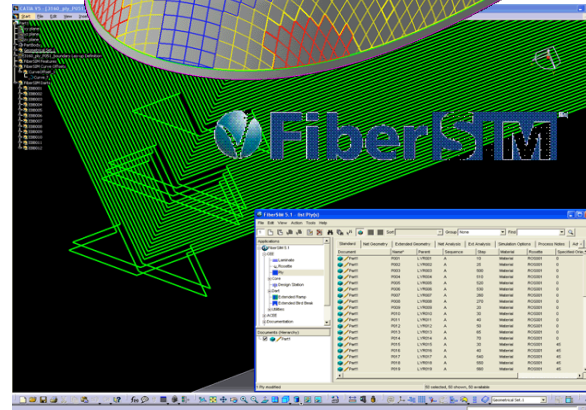
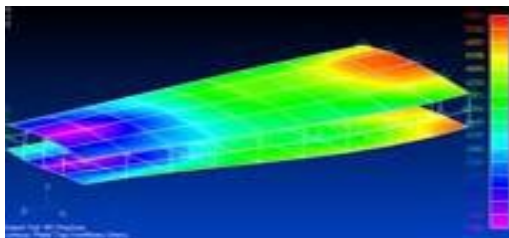
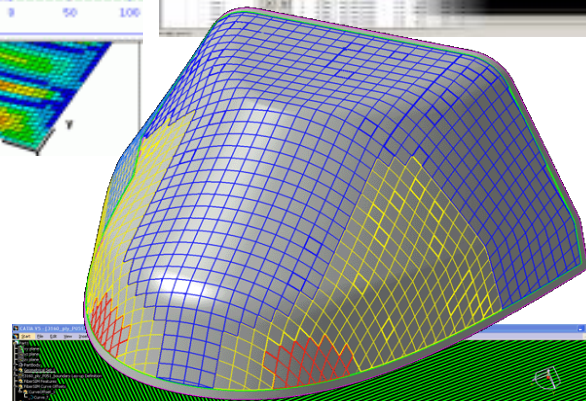
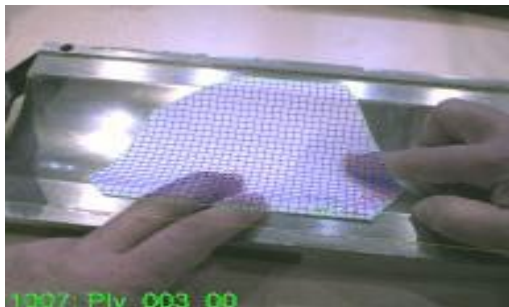
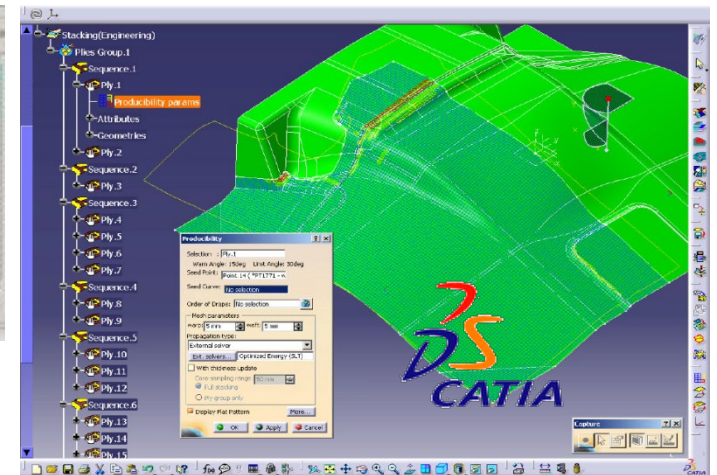
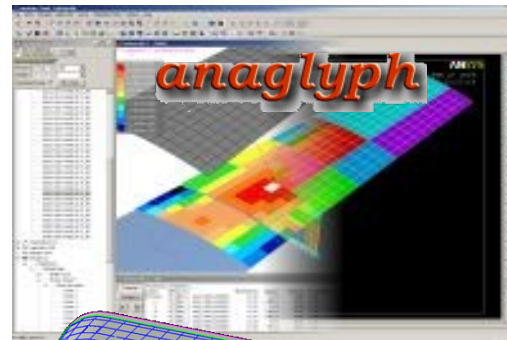
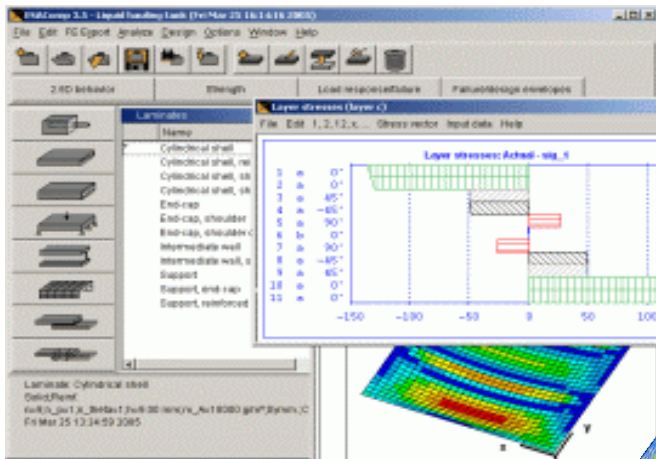

Composites Design Software

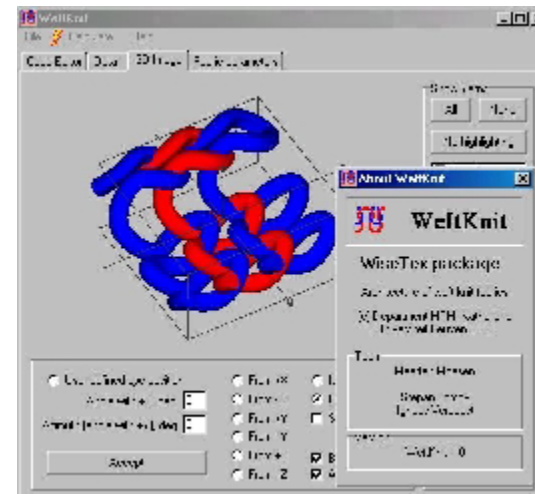
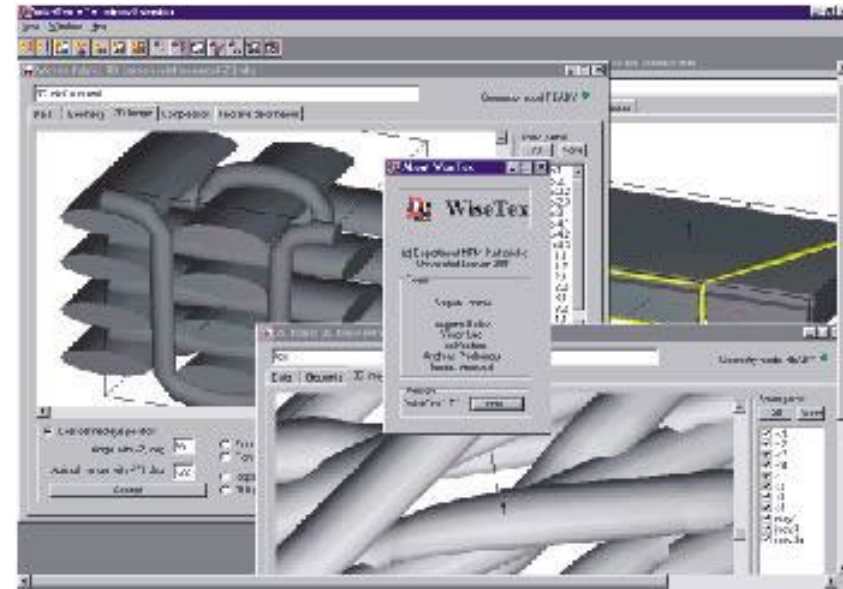
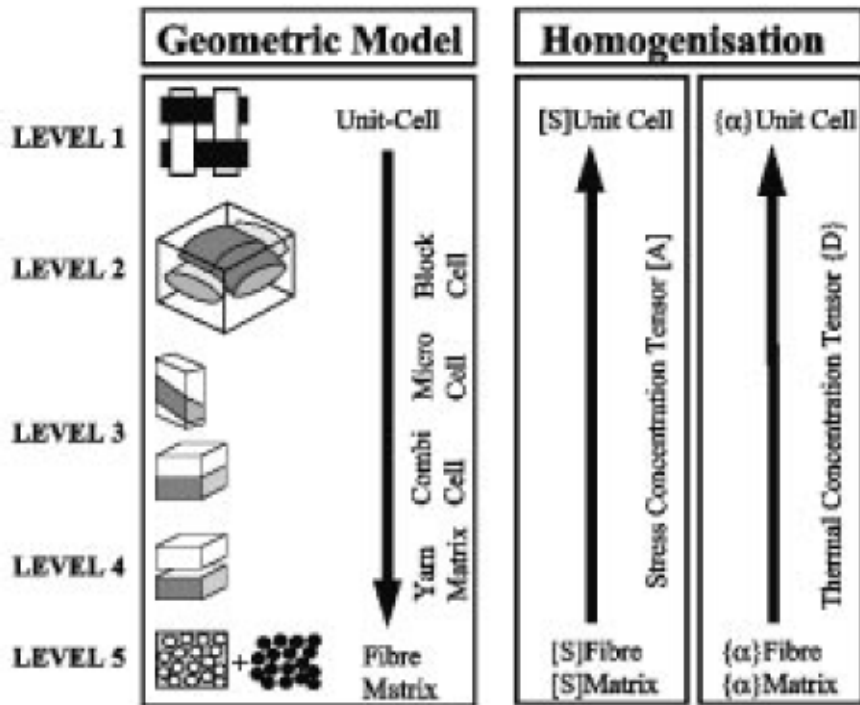

Modeling fabric properties : Wisetex

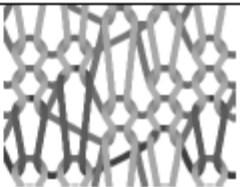

Coding of fibre architectures

Principle	Example	Picture																
2D and 3D woven																		
Matrix where (i,j) element gives a layer of intersection of i -th warp with j -th weft row (Lomov et al. 2000)	<table border="1"> <tr><td>1</td><td>0</td><td>2</td><td>1</td></tr> <tr><td>1</td><td>0</td><td>2</td><td>1</td></tr> <tr><td>1</td><td>0</td><td>2</td><td>1</td></tr> <tr><td>1</td><td>0</td><td>2</td><td>1</td></tr> </table>	1	0	2	1	1	0	2	1	1	0	2	1	1	0	2	1	
1	0	2	1															
1	0	2	1															
1	0	2	1															
1	0	2	1															
Weft-knitted																		
A matrix entry represents an individual needle action and is a combination of the position of the needle and the stitch type (Lomov et al. 2001)	<table border="1"> <tr><td></td><td>+</td><td>X</td><td>X</td></tr> <tr><td>+</td><td>X</td><td>X</td><td>X</td></tr> <tr><td>X</td><td>X</td><td>X</td><td>+</td></tr> <tr><td>X</td><td>X</td><td>+</td><td></td></tr> </table>		+	X	X	+	X	X	X	X	X	X	+	X	X	+		
	+	X	X															
+	X	X	X															
X	X	X	+															
X	X	+																
Warp-knitted																		
A sequence of position of guides in relation to needles in the bed (Spencer 1997)	<table border="1"> <tr><td>1</td><td>-0</td><td>1</td><td>-</td></tr> <tr><td>2</td><td>2</td><td>-1</td><td>/</td></tr> </table>	1	-0	1	-	2	2	-1	/									
1	-0	1	-															
2	2	-1	/															



Models of woven fabrics built with WiseTex

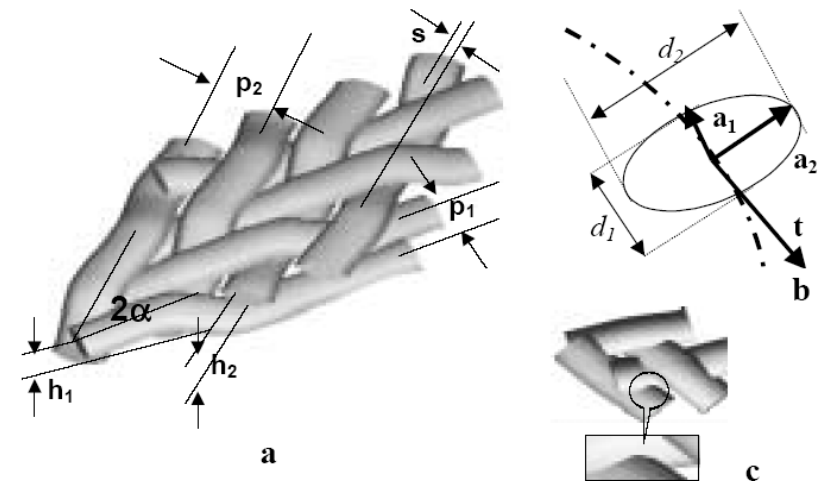
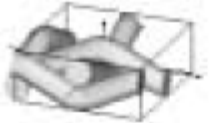









Figure 3 Yarns in flat braid: (a) Spacing p , crimp heights h and side crimp s of the yarns and a braiding angle α ; (b) Vectors characterising the cross-section; (c) Intermixing volumes of yarns (no rotation of cross-sections).

Deformation

Table 2. Tension along warp of a model fabric:
incompressible circular yarns

Fixed weft	$e_x, \%$	Free weft
	0	
	5	
	10	
	15	

Predicted and measured properties

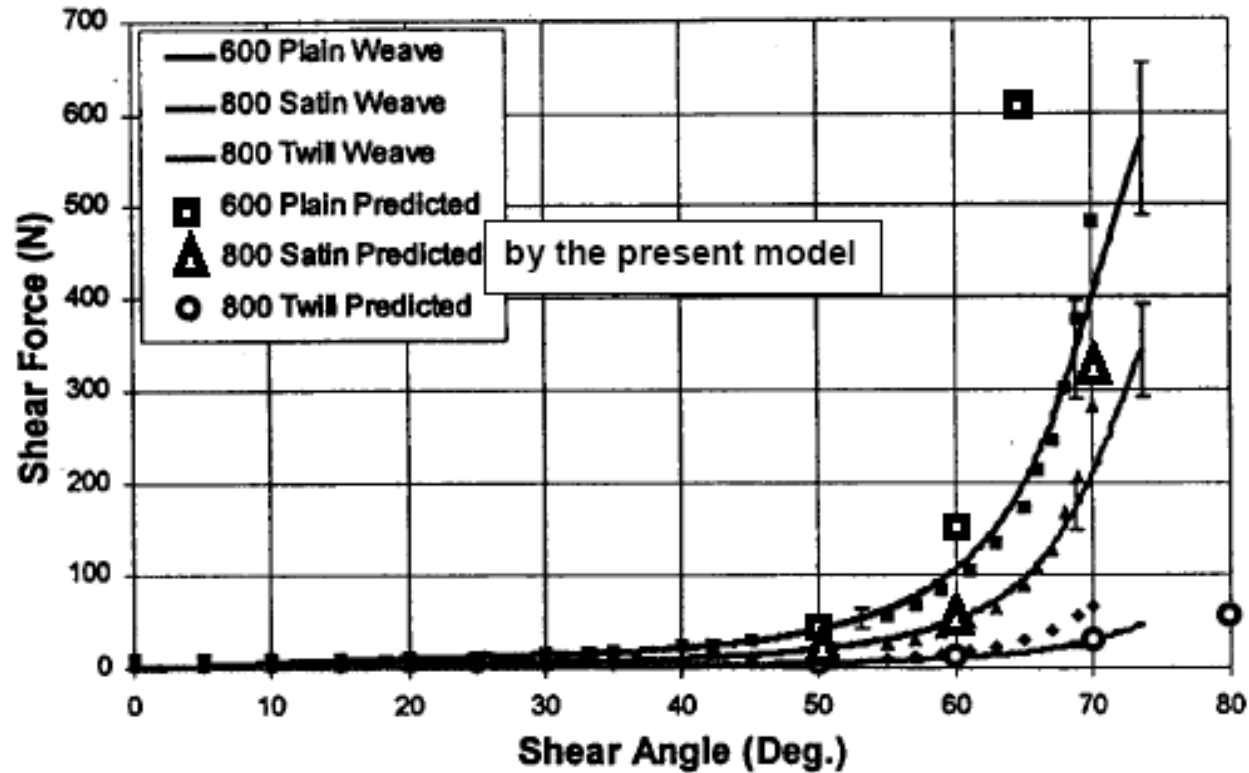

Current development

WiseTex model of the fabric accounts for the “twin” placement of yarns in the fabric and non-circular shape of the yarns.

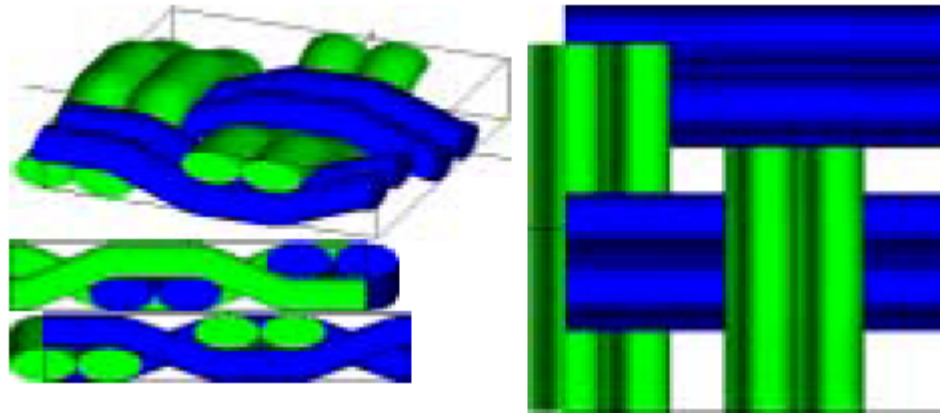

Beyond mechanical properties

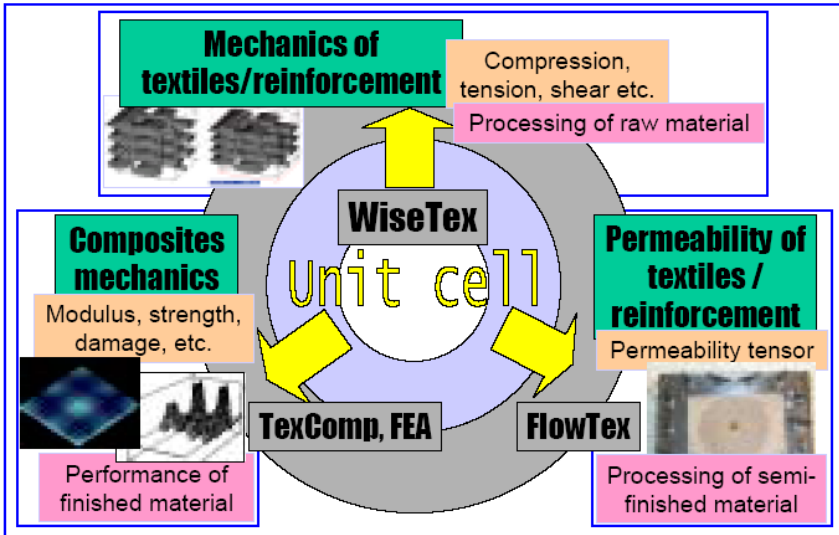

Integrated Design Tool: textile composites

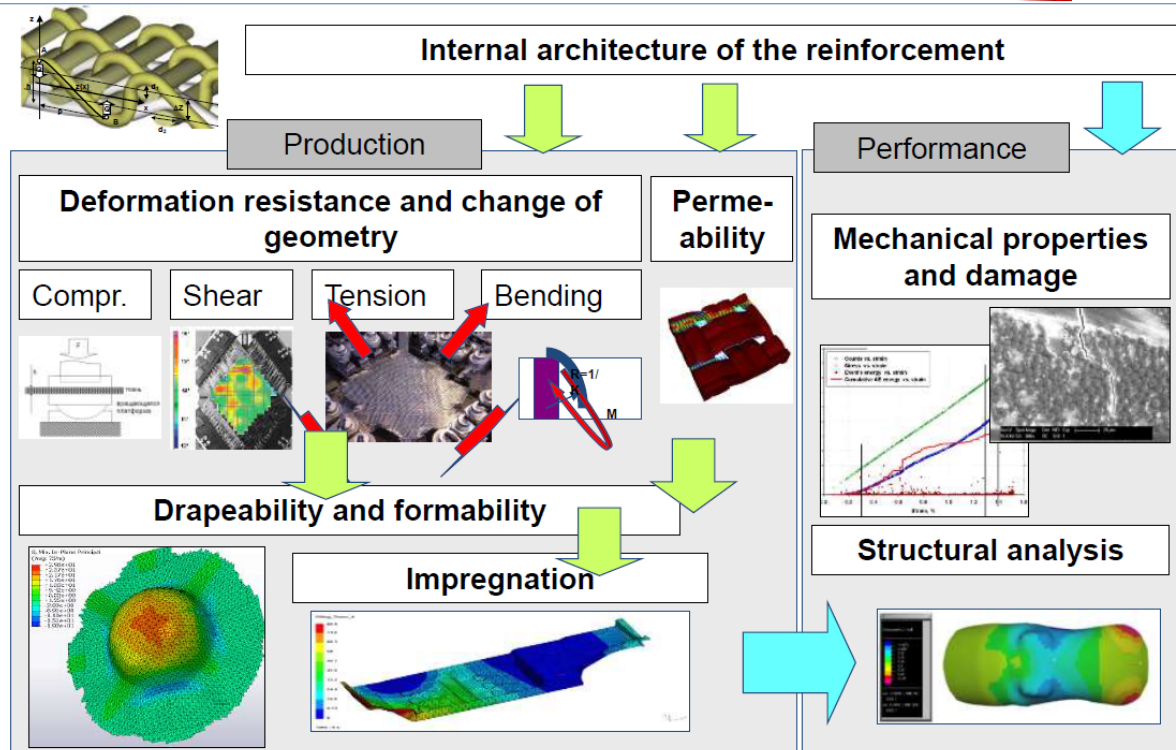

SV Lomov

4

KU LEUVEN

MATERIALS ENGINEERING

<https://www.mtm.kuleuven.be/onderzoek/scalint/Composites/software/wisetex>

Permeability

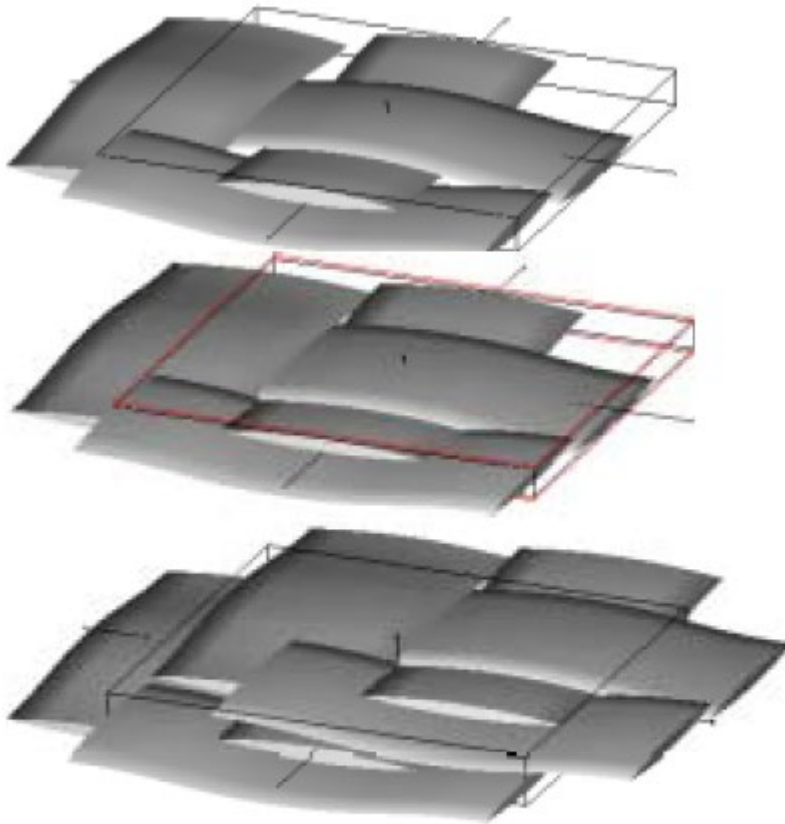
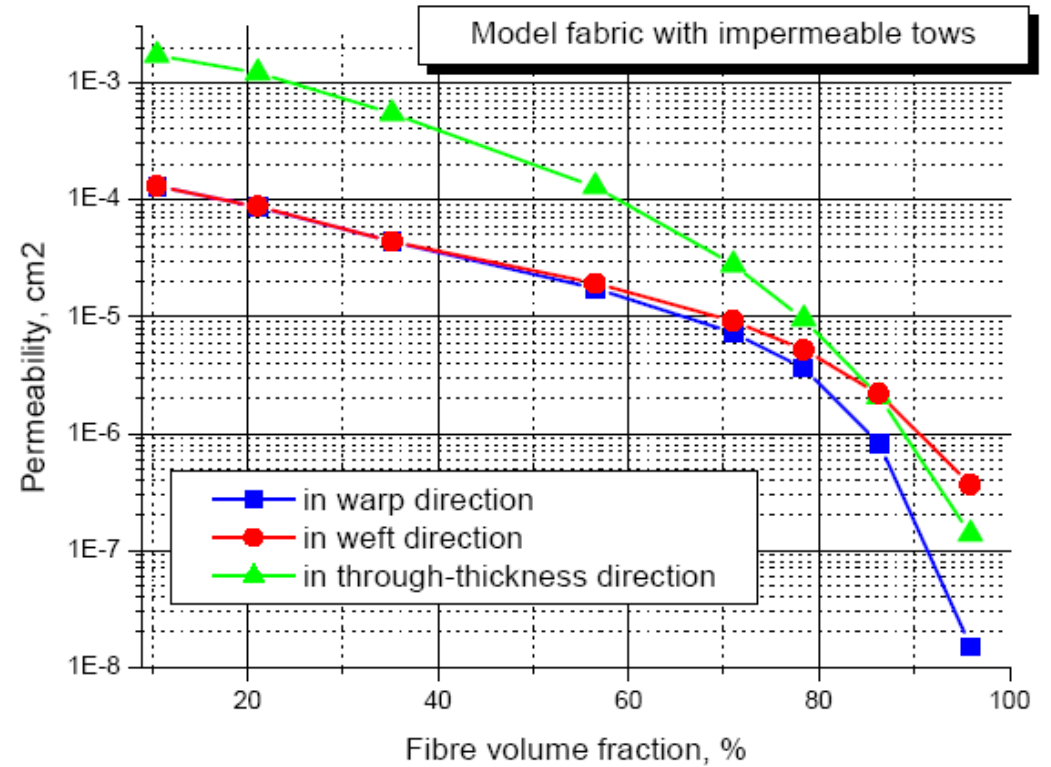



Figure 3. Relaxed geometry model of plain-weave (above), compressed geometry model (middle), two-layer compressed geometry model (below)



Comparisons



Short fibres



Mats

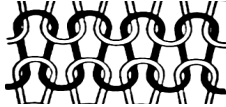

Knits

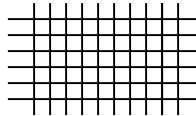

Weaves



Braids



UD

Laminates

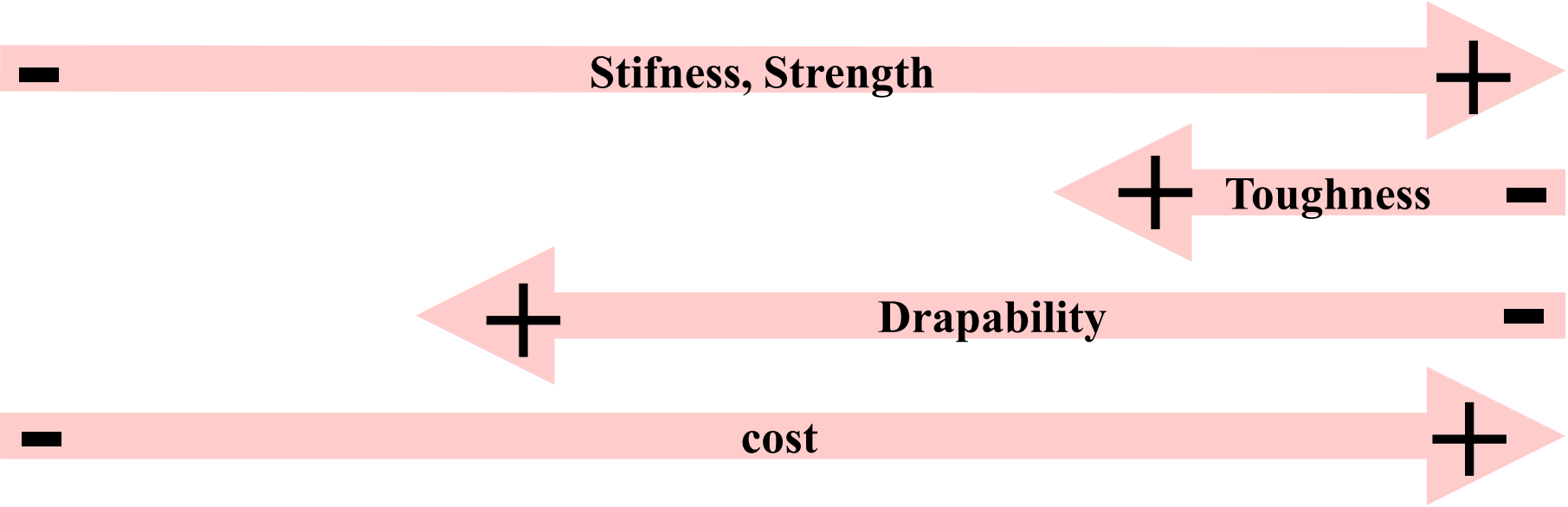

Comparisons of composite textile structures

Textile Process	Advantages	Limitations
Low Crimp Uniweave	High in-plane properties Good tailorability Highly automated preform fabrication process	Low transverse and out-of-plane properties Poor fabric stability Labor intensive ply lay-up
2-D Woven Fabric	Good in-plane properties Good drapability Highly automated preform fabrication process Integrally woven shapes possible Suited for large area coverage Extensive data base	Limited tailorability for off-axis properties Low out-of-plane properties
3-D Woven Fabric	Moderate in-plane and out-of-plane properties Automated preform fabrication process Limited woven shapes possible	Limited tailorability for off-axis properties Poor drapability
2-D Braided Preform	Good balance in off-axis properties Automated preform fabrication process Well suited for complex curved shapes Good drapability	Size limitation due to machine availability Low out-of-plane properties
3-D Braided Preform	Good balance in in-plane and out-of-plane properties Well suited for complex shapes	Slow preform fabrication process Size limitation due to machine availability
Multiaxial Warp Knit	Good tailorability for balanced in-plane properties Highly automated preform fabrication process Multi-layer high throughput material suited for large area coverage	Low out-of-plane properties
Stitching	Good in-plane properties Highly automated process provides excellent damage tolerance and out-of-plane strength Excellent assembly aid	Small reduction in in-plane properties Poor accessibility to complex curved shapes

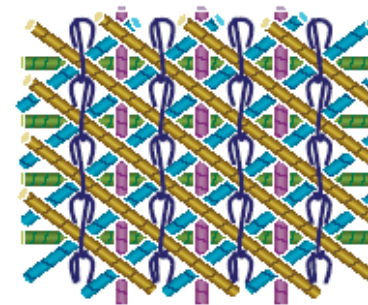

Multiaxial warp knit (stitched & unstitched)



2-D triaxial braid (stitched & unstitched)

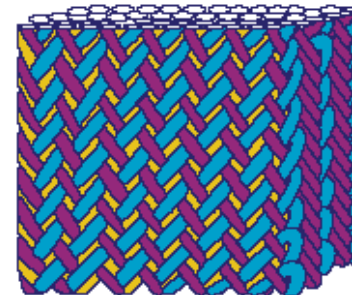

3-D braid

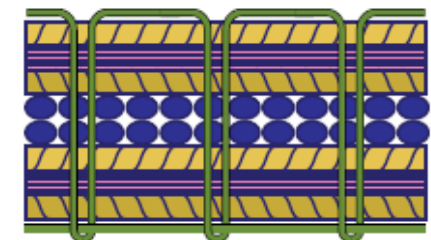

Knitted/stitched

Effect of stitching on damage tolerance

Details of stitched plates

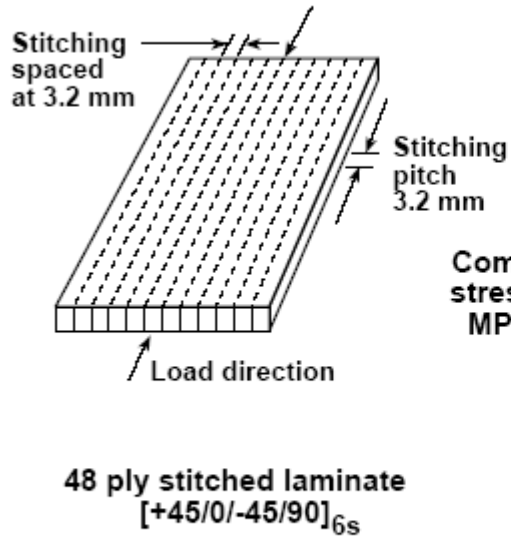

Compression after impact strength

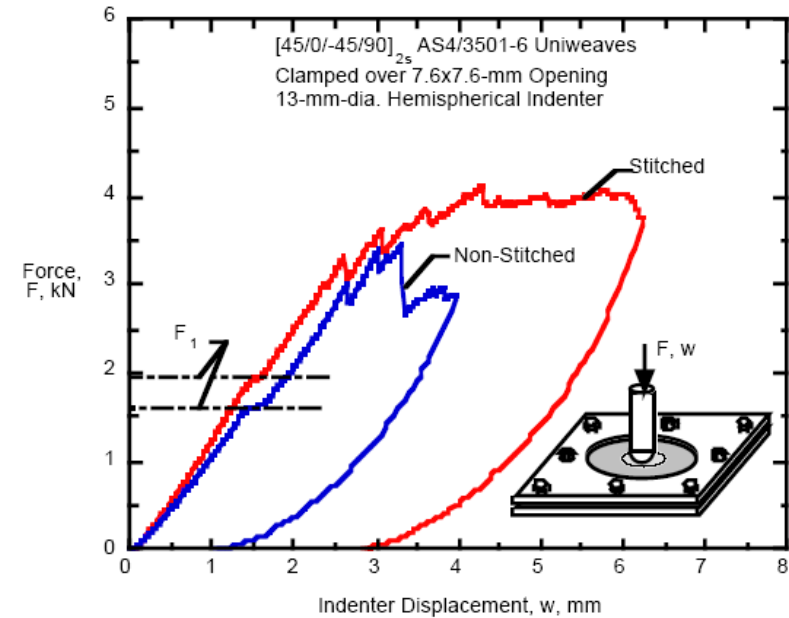
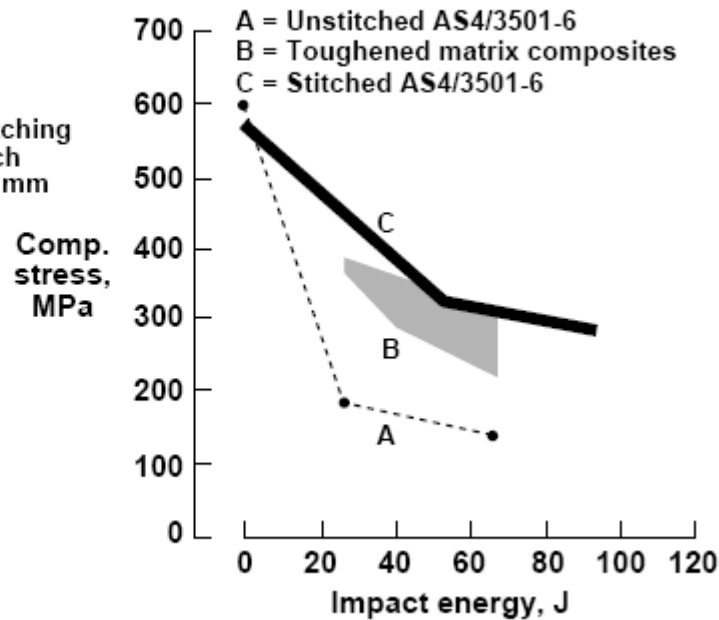

Toughness

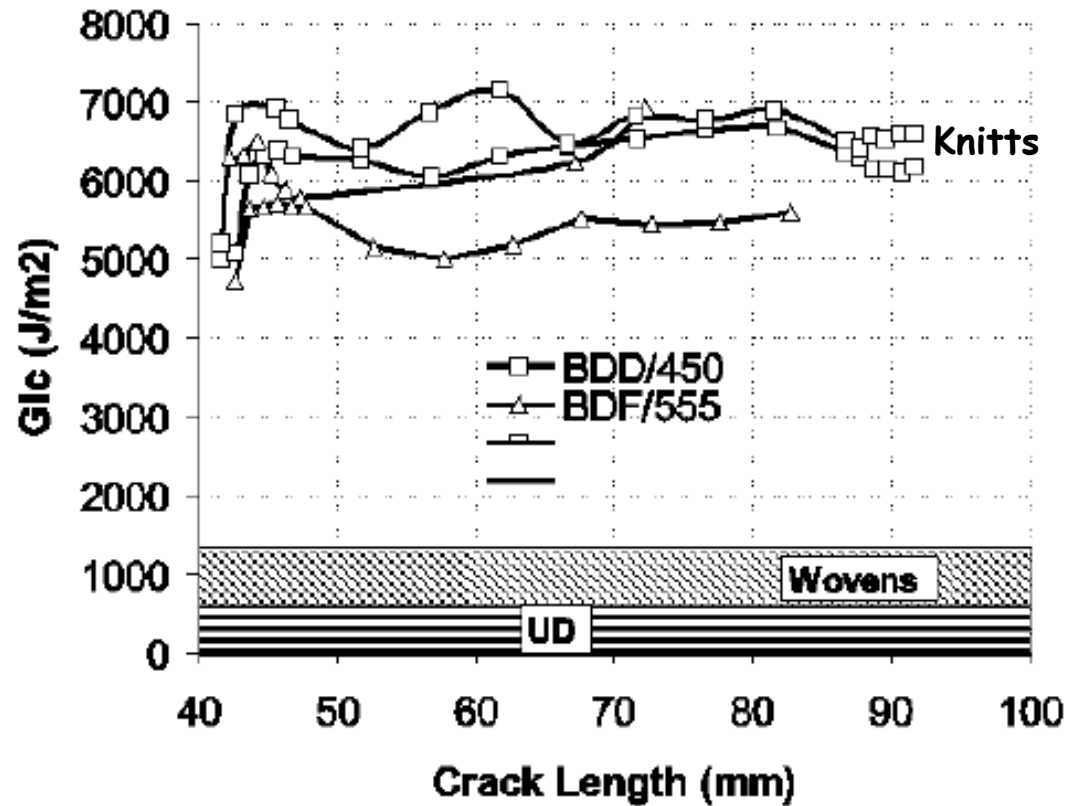

Mode I fracture toughness of glass/epoxy composites tested in the wale direction

Lighter...



Fig. 1: The complete bike

JEC COMPOSITES MAGAZINE / No76 October - Novembre

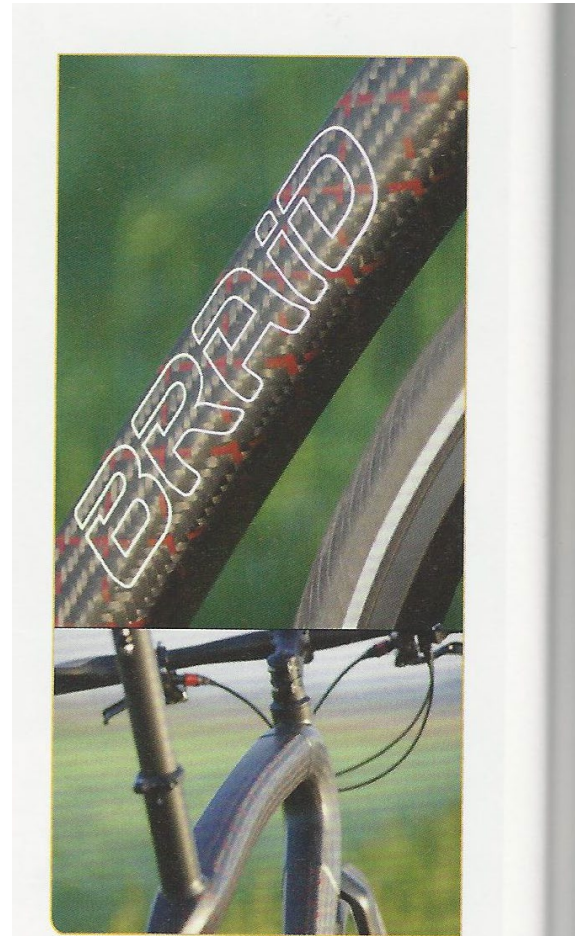
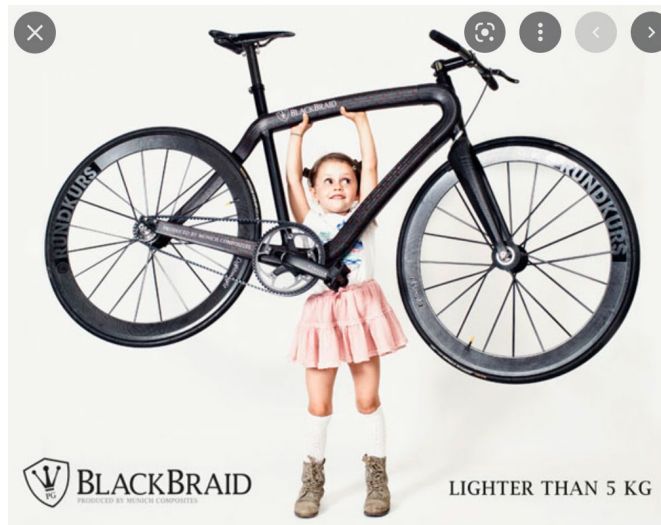

AI optimization - 3D anisotropic design

Energy Efficient Lightweight
Composite Architected Structures

WINNER

CAMX Award for Composite Excellence (ACE)

<https://www.carbonform3d.com/>

